

martin®

Martin® ***DT2*** ***Inline Cleaner***

[Go to Martin® DT2 Inline Cleaner web page](#)



Operator's Manual
M3687

Important

MARTIN ENGINEERING HEREBY DISCLAIMS ANY LIABILITY FOR: DAMAGE DUE TO CONTAMINATION OF THE MATERIAL; USER'S FAILURE TO INSPECT, MAINTAIN AND TAKE REASONABLE CARE OF THE EQUIPMENT; INJURIES OR DAMAGE RESULTING FROM USE OR APPLICATION OF THIS PRODUCT CONTRARY TO INSTRUCTIONS AND SPECIFICATIONS CONTAINED HEREIN. MARTIN ENGINEERING'S LIABILITY SHALL BE LIMITED TO REPAIR OR REPLACEMENT OF EQUIPMENT SHOWN TO BE DEFECTIVE.

Observe all safety rules given herein along with owner and Government standards and regulations. Know and understand lockout/tagout procedures as defined by American National Standards Institute (ANSI) z244.1-1982, *American National Standard for Personnel Protection - Lockout/Tagout of Energy Sources - Minimum Safety Requirements* and Occupational Safety and Health Administration (OSHA) Federal Register, Part IV, 29 CFR Part 1910, *Control of Hazardous Energy Source (Lockout/Tagout); Final Rule*.

The following symbols may be used in this manual:



Danger: Immediate hazards that will result in severe personal injury or death.



Warning: Hazards or unsafe practices that could result in personal injury.



Caution: Hazards or unsafe practices that could result in product or property damages.



Important: Instructions that must be followed to ensure proper installation/operation of equipment.



Note: General statements to assist the reader.

Table of Contents

Section	Page
List of Figures/Tables	ii
Introduction	1
General	1
Installations Without Chutework	1
Belt Cleaner Inspection Access	1
References	2
Safety	2
Materials Required	2
Urethane Shelf Life	2
Before Installing Belt Cleaner	3
Installing Belt Cleaner	4
Locating Cleaner Centerline	4
Converting Bottom Mount Spring Tensioners to Top Mount	6
Marking Chute Cutouts	8
Adjusting the Spring Tensioner	10
Adjusting the Air Tensioner	11
After Installing Belt Cleaner	13
Maintenance	15
Routine Inspection/Tension	15
Blade Servicing	15
Troubleshooting/Installation Checklist	18
Troubleshooting	18
Installation Checklist	18
Part Numbers	19

List of Figures

Figure	Title	Page
1a	Belt Direction	5
1b	Belt Direction	5
2	Spring Tensioner Conversion	6
3	Chute Cutout Detail	8
4	Spring Tensioner Operation	10
5	Air Tensioner Operation.	12
6a	Cleaner Changing Belt Line	13
6b	Cleaner with Belt Support	13
7a	Martin [®] DT2 Inline Cleaner with Inline Blades and Air Tensioner, P/N DT2S-XXXXXXXXXA	20
7b	Martin [®] DT2 Inline Cleaner with Air Tensioner, P/N DT2S-XXXXXXXXXA	21
8a	Martin [®] DT2 Inline Cleaner with Inline Blades and Spring Tensioner, P/N DT2S-XXXXXXXXXS.	25
8b	Martin [®] DT2 Inline Cleaner with Spring Tensioner, P/N DT2S-XXXXXXXXXS.	26,27
9a	Martin [®] DT2 Inline Cleaner Cartridge, P/N DT2SC-XXXXXXXXXX	30
9b	Martin [®] DT2 Inline Cleaner Cartridge, P/N DT2SC-XXXXXXXXXX	31
10	Conveyor Products Warning Label, P/N 23395	34
11	Pinch Point Warning Label, P/N 30528	34

List of Tables

Table	Title	Page
I	Urethane Shelf Life	2
II	Recommended Spring Tension and Air Pressure	11
III	Martin [®] DT2 Inline Cleaner with Air Tensioner	22
IV	Martin [®] DT2 Inline Cleaner with Spring Tensioner	27
V	Martin [®] DT2 Inline Cleaner Cartridge.	31

Introduction

General

The Martin[®] DT2 Inline Cleaner is used in conjunction with a head pulley primary cleaner such as a Martin[®] Primary Cleaner.

The Martin[®] DT2 Inline Cleaner contacts the belt as it leaves the head pulley or another accessible position on the return belt with proper support. The blades of the Martin[®] DT2 Inline Cleaner, when tensioned, lay in the direction of belt travel giving a negative angle and presenting no snag or danger to the belt or splices.

The cleaner can be supplied or retrofitted with a variety of cleaning blades. These include:

- Tungsten Carbide Blades—For very abrasive materials.
- Reversing Blades—All above options in reversing form for belts that drive in both directions.

Note: When mounted slightly away from the head pulley or pressure roller, the standard Martin[®] DT2 Inline Cleaner Blade will handle small amounts of belt reversal or rollback with no adverse effects. When fitted with Reversing Blades, the Martin[®] DT2 Inline Cleaner becomes a fully-operational reversing belt cleaner.

If the material-handling process or product could be affected by contamination from the use of these belt cleaners, the user is responsible for taking the necessary steps to prevent contamination. Consult Martin Engineering or a representative for alternate belt cleaners or belt cleaner locations to use where contamination may be an issue.

The Martin[®] DT2 Inline Cleaner is protected by U.S. patent number 6,581,754 and international patents pending and issued.

Installations Without Chutework

These procedures were written for equipment that is being installed on enclosed pulley chutework. If the pulley is not enclosed, the equipment should be installed using the best available field resources and methods to ensure that the critical dimensions are followed for proper installation.

The Martin[®] Reversing Hanger Mount Weldment, P/N 33282, can be used for installations without chutework.

Belt Cleaner Inspection Access

If the belt cleaner is installed on enclosed pulley chutework, a Martin[®] Inspection Door should be installed. Martin[®] Inspection Doors are available from Martin Engineering or your representative.

References

The following documents are referenced in this manual:

- American National Standards Institute (ANSI) z244.1-1982, *American National Standard for Personnel Protection - Lockout/Tagout of Energy Sources - Minimum Safety Requirements*, American National Standards Institute, Inc., 1430 Broadway, New York, NY 10018.
- Federal Register, Volume 54, Number 169, Part IV, 29 CFR Part 1910, *Control of Hazardous Energy Source (Lockout/Tagout); Final Rule*, Department of Labor, Occupational Safety and Health Administration (OSHA), 32nd Floor, Room 3244, 230 South Dearborn Street, Chicago, IL 60604.
- *Martin® Inspection Door Operator’s Manual*, P/N M3891.

Safety

All safety rules defined in the above documents and all owner/employer safety rules must be strictly followed when working on the belt cleaner.

Materials Required

Only standard hand tools are required to install and service this equipment.

IMPORTANT

Urethane put in service after exceeding its shelf life may wear differently and deteriorate quicker than normal urethane.

Urethane Shelf Life

NOTE

Code Date is written near bottom of blade as mm/dd/yy-x. In addition to or in place of this date, you may see an imprinted date medallion similar to the example shown. In this example, “14” stands for the year 2014. The small circles represent the quarter of the year. If three circles are “punched” the blade was produced in the first quarter. If none of the circles are “punched” the blade was produced in the fourth quarter. If code date on your blade(s) is not legible or is missing, contact Martin Engineering or a representative.

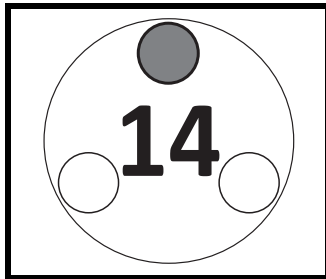

Table I. Urethane Shelf Life

Blade Color	Shelf Life
Blue	1 Year from Code Date
Brown	2 Years from Code Date
Clear	1 Year from Code Date
Green	2 Years from Code Date
Orange	1 Year from Code Date

Before Installing Belt Cleaner

1. Remove belt cleaner from shipping container. Equipment in container should include the following:
 - Martin® DT2 Inline Cleaner (mainframe, tensioner, and blades).
 - Two Conveyor Products Warning Labels, P/N 23395.
 - Two Pinch Point Warning Labels, P/N 30528.
2. If anything is missing or damaged, contact Martin Engineering or a representative. Keep any damaged goods subject to examination.

⚠ WARNING

Before installing equipment, turn off and lock out/tag out energy source to conveyor and conveyor accessories.

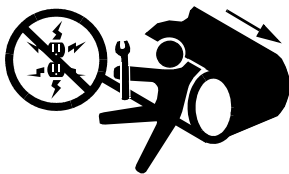

3. Turn off and lock out/tag out energy source according to ANSI standards (see “References”).

⚠ WARNING

If equipment will be installed in an enclosed area, gas level or dust content must be tested before using a cutting torch or welding. Using a cutting torch or welding in an area with gas or dust may cause an explosion.



4. If using a cutting torch or welding, test atmosphere for gas level or dust content. Cover conveyor belt with fire retardant cover.

NOTE

The chute wall that is easiest to access is referred to as the “operator side.” The other side of the chute is referred to as the “far side.”

5. Determine which side of chute is easiest to access. Locate the operator side tensioner on the most accessible chute wall and the far side tensioner on the other side of the chute.

Installing Belt Cleaner

IMPORTANT

Read entire section before beginning work.

To install the belt cleaner, follow the procedures corresponding to the following steps:



WARNING

If installation is to be done in an enclosed area, test atmosphere for gas level or dust content. Follow all welding and safety guidelines. Protect belt surface from weld splatter with appropriate shield.

NOTE

For original equipment installation, where cleaner cutouts and brackets have been fabricated into the chute during construction, ignore steps 1, 2, and 3.

NOTE

Solid backing of the blade is essential to ensure proper operation and efficient cleaning. Install the cleaner adjacent to the head pulley or a flat pressure roller to obtain best cleaning results. See Figures 1a and 1b.

NOTE

For installation on enclosed head pulley chutework, draw all dimension lines on chute wall. In applications where head pulley is not enclosed, use the best available field resources and/or methods to ensure that these critical dimensions are followed for a proper installation.

Locating Cleaner Centerline

1. On the return side of the belt, locate the tangent point at which the belt leaves the head pulley. Measure a distance 2.0 in. (51 mm) and draw a line perpendicular to the belt at this point. See Figures 1a and 1b.

NOTE

For installation below pressure rollers, mark the vertical line 2 in. (51 mm) from the centerline of the roller. See Figure 1a.

2. This line represents the centerline of the Martin® DT2 Inline Cleaner and the cleaner mount brackets.

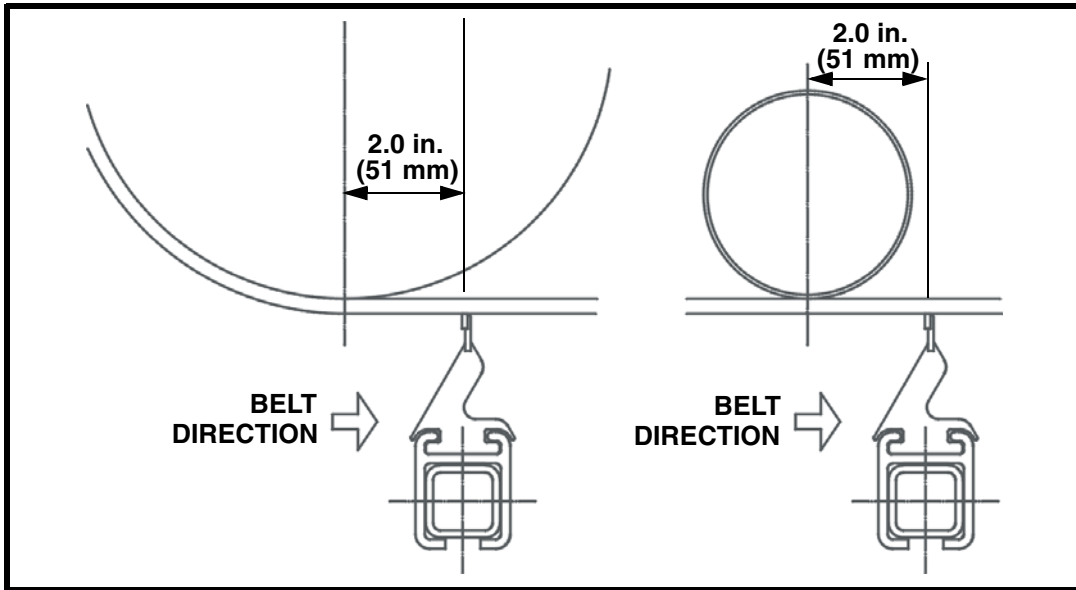

Figure 1a. Belt Direction

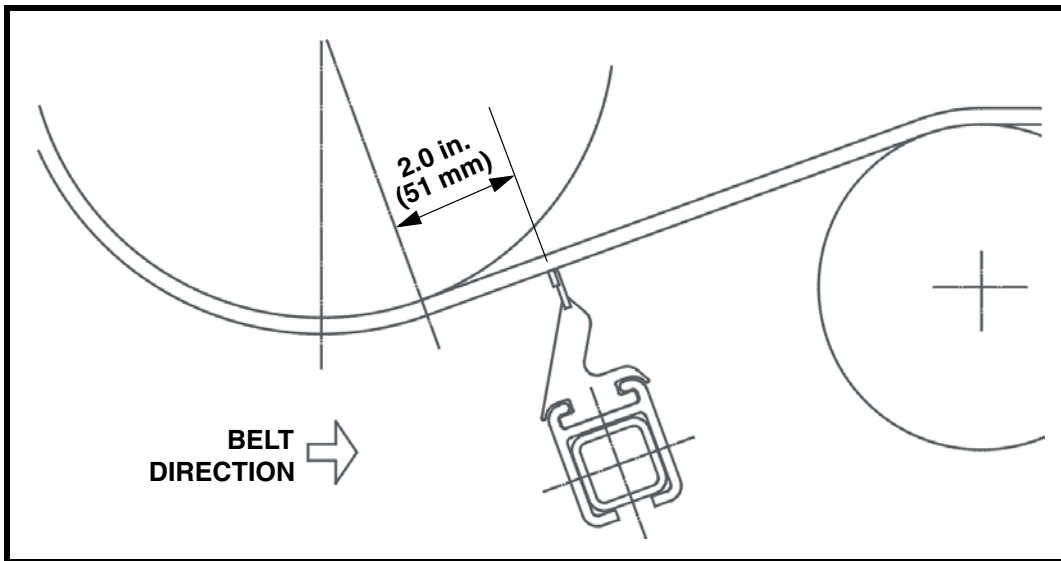

Figure 1b. Belt Direction

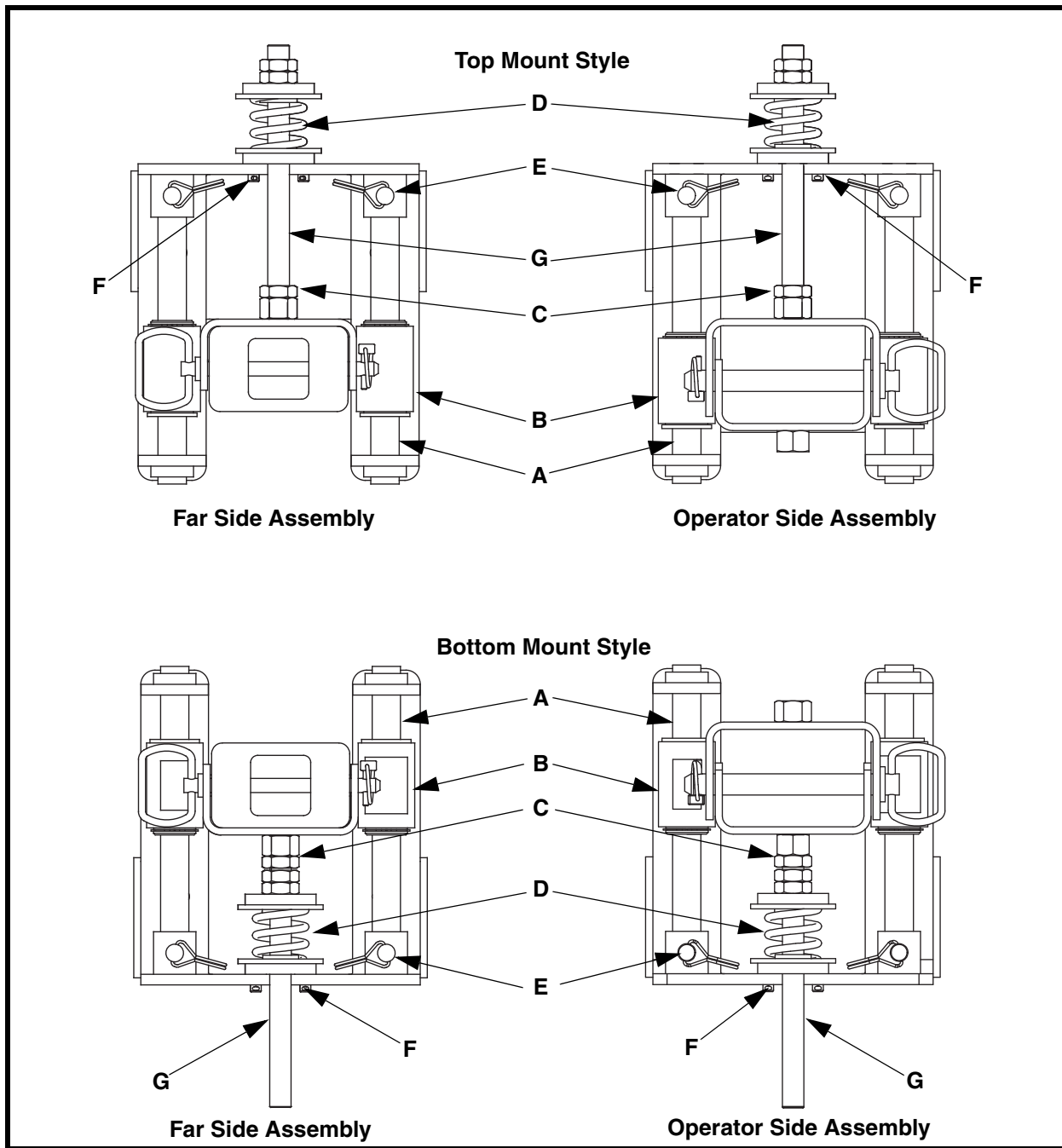

Figure 2. Spring Tensioner Conversion

Converting Bottom Mount Spring Tensioners to Top Mount

1. If using spring tensioner, determine how much space is available for spring tensioner installation. If necessary, convert bottom mount spring tensioner to top mount before installing. See Figure 2.
2. Convert operator side assembly as follows:
 - a. Loosen jam nut (C).
 - b. Remove cotter pins (F).
 - c. Remove threaded rod (G) and spring assembly (D) from slide bracket (B).
 - d. Install jam nut (C) on opposite end of threaded rod.

- e. Remove pins (E) and guide rods (A) from mount bracket.
 - f. Rotate slide bracket 180 degrees and reinstall guide rods and pins.
 - g. Rotate threaded rod and spring assembly 180 degrees and install on top of mount plate. Install threaded rod into slide bracket.
 - h. Install cotter pins.
3. Convert far side assembly as follows:
- a. Loosen jam nut (C).
 - b. Remove cotter pins (F).
 - c. Remove threaded rod (G) and spring assembly (D) from slide bracket (B).
 - d. Install jam nut (C) on opposite end of threaded rod.
 - e. Rotate threaded rod and spring assembly 180 degrees and install on top of mount plate. Install threaded rod into slide bracket.
 - f. Install cotter pins.

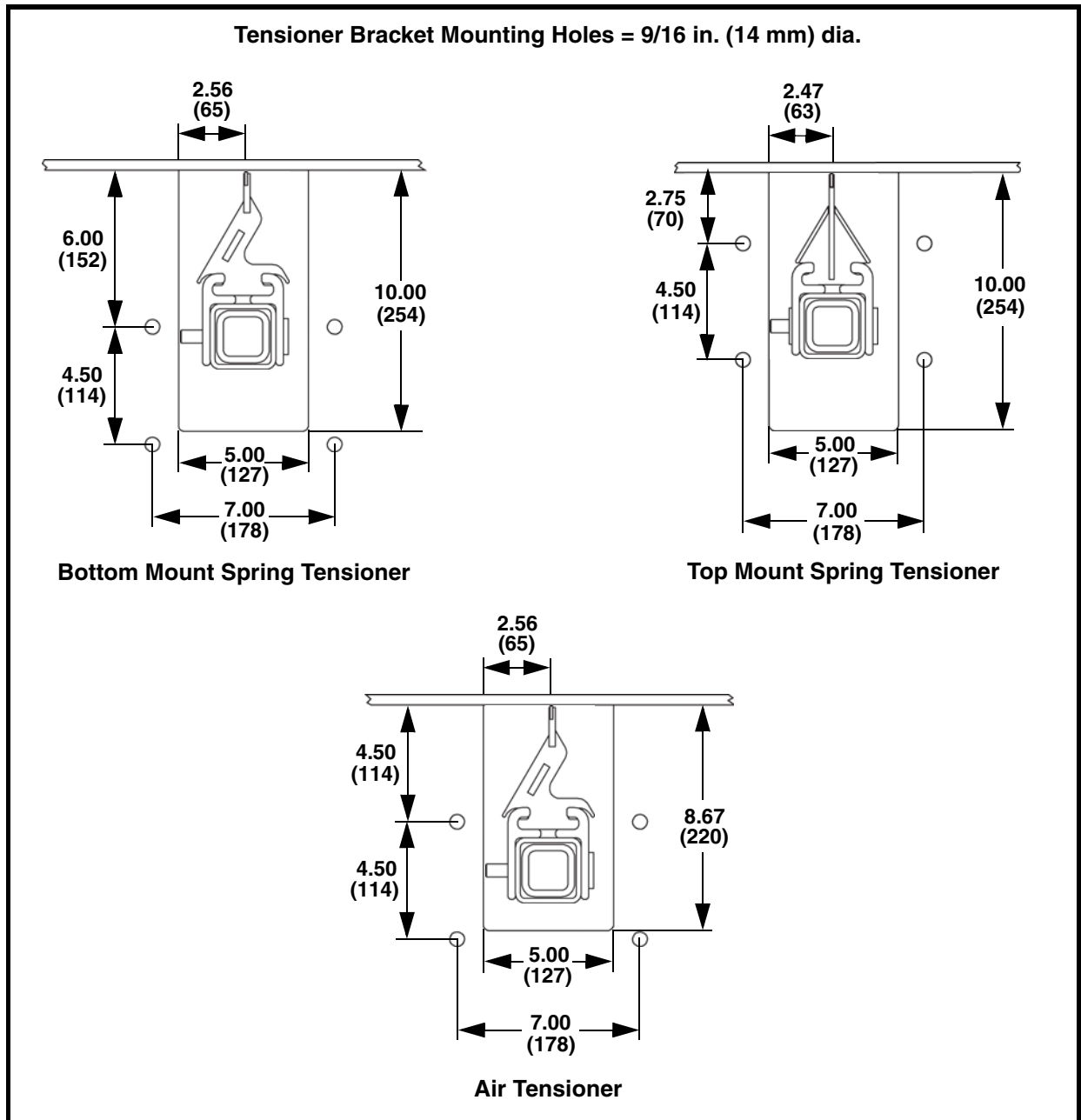

Figure 3. Chute Cutout Detail

Marking Chute Cutouts

1. Using the previously marked line as the centerline, mark the chute cutout and mount hole locations as shown in Figure 3. Repeat on both sides of chute, ensuring the cutouts are accurately aligned with each other.

NOTE

The mount hole dimension below the belt differs for air- or spring-tensioned models. Make sure that you are using correct dimensions and verify cleaner position before proceeding.

2. At the selected mounting positions, cut the cleaner access slots and drill the mount holes in each side of the chute. Dress and de-burr the holes and cutouts.
3. If belt width is 54" or larger, replace 1-3/4" long spring, upper flat washer and UHMW spring retainer with 2" long spring and 3/4" washer included.
4. Fit operator side mount bracket to the chute wall. Bolt mount to the chute wall.
5. Repeat for far side mount bracket.
6. Fit the cleaner mainframe to the mounts. Slide the mainframe into one of the mount brackets, through the cutout in the chute wall, then through the cutout and mount on the opposite side.

NOTE

The mainframe has holes at one end. This is the end that fits to the operator side mount.

7. Align the end of the mainframe with the outer edge of the operator side mount bracket and refit the locking screw, taking care to fit the air line bracket under the screw (air tensioner models only). At the far side mount, tighten the lock screw onto the mainframe.

NOTE

The mainframe in most cases will have excess length. If required, this excess can be trimmed from the far side end.

8. Slide the blade cartridge onto the mainframe from the operator side. If the cartridge is too long, excess can be trimmed from the non-operator end. If not already done, fit the cleaning blades to the cartridge. Center the blades to the belt by loosening and re-positioning the blade end stops. Insert the blade cartridge retaining pin.
9. With the cleaner tensioner in a fully retracted position, the cleaning blades should be approximately .5 in.–.75 in. (13 mm–19 mm) clear of the underside of the belt and this distance should be equal across the width of the belt.
10. If necessary, loosen and adjust the mounts up or down to achieve this clearance.
11. Once all clearances are correct, thoroughly check all mounting and locking screws to ensure they are tight and the cleaner is secured.
12. For the air-tensioned model only, connect the air tube to the fittings in the far side airbag on the underside of the mount bracket. See Figure 5.
13. Pass the tube through the mainframe. (Make sure tube is located underneath handle.) Connect the tube to the tee air fitting in the operator side airbag adjusting the tube length to suit by cutting.
14. Connect the other side of the tee fitting to the incoming regulated compressed air supply or to the outlet of air regulator kit, if used. Connect the plant air supply or air supply kit to the inlet side of the regulator kit.

Adjusting the Spring Tensioner

1. Loosen the lock nut above the spring. Repeat for both sides.
2. Turn adjusting nut (equally on both sides) until cleaner blades are lightly touching the belt.
3. Ensure the blade position is equal across belt and blades are lightly touching across belt width.
4. Continue turning the adjusting nut equally on both sides until the spring-compressed length is the same as indicated in Table II.
5. Tighten the lock nuts against the adjusting nuts.

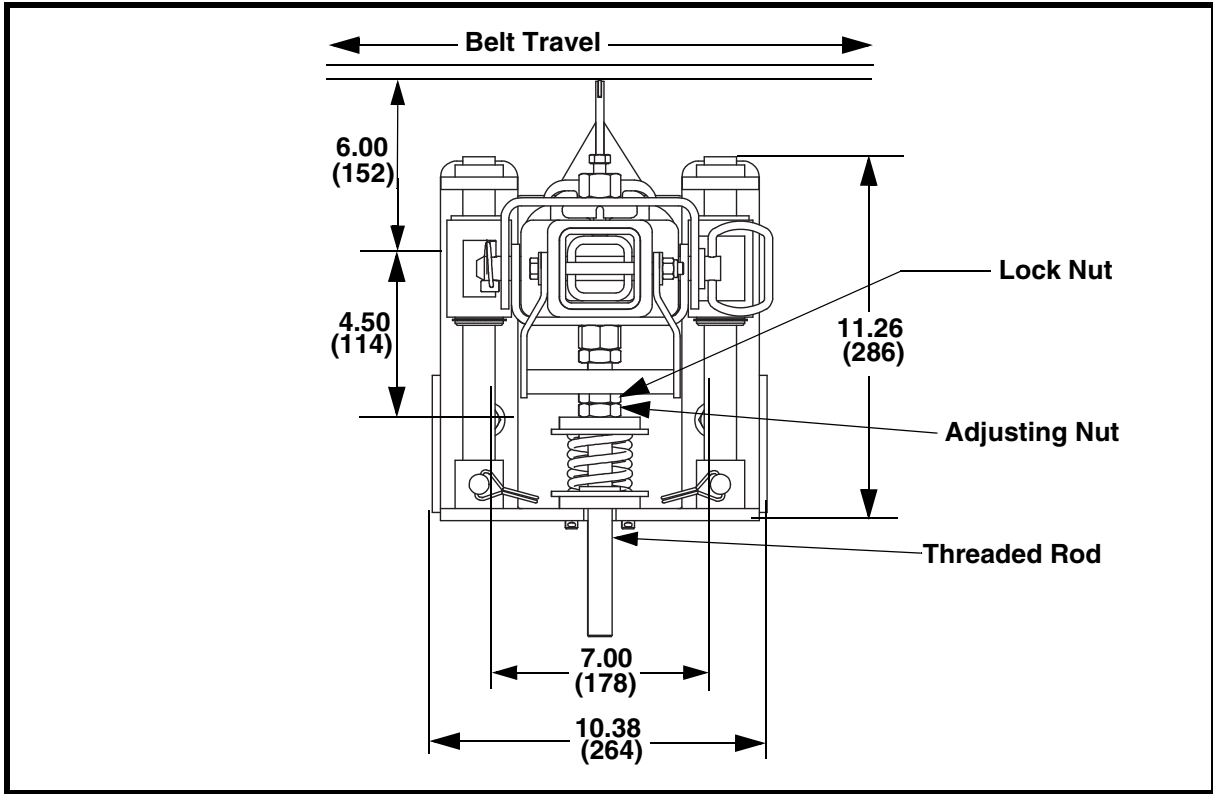

Figure 4. Spring Tensioner Operation

Table II. Recommended Spring Tension and Air Pressure

Belt Width in. (mm)	Air Tensioner psi (bar)	Spring Tensioner Compressed Spring Length in. (mm)
18 (457)	2 (0.14)	1.625 (41)
24 (610)	2 (0.14)	1.625 (41)
30 (762)	3 (0.21)	1.500 (38)
36 (914)	3 (0.21)	1.500 (38)
42 (1067)	4 (0.28)	1.500 (38)
48 (1219)	4 (0.28)	1.500 (38)
54* (1372)	5 (0.34)	1.750 (44)
60* (1524)	6 (0.41)	1.750 (44)
66* (1676)	6 (0.41)	1.750 (44)
72* (1829)	7 (0.49)	1.625 (41)
84* (2134)	7 (0.49)	1.625 (41)
96* (2438)	8 (0.55)	1.625 (41)
120* (3048)	10 (0.69)	1.500 (38)

*For belt widths 54 in. and above, replace 1-3/4" long spring, upper flat washer and UHMW spring retainer with 2" long spring and 3/4" washer included.

Adjusting the Air Tensioner

The air tensioner utilizes an inflatable air bag on each cleaner mount to provide the force to adjust the blades against the belt. Cleaner adjustments and correct force are automatically applied by simple air pressure control. See Figure 5.

1. Adjusting the air-tensioned Martin[®] DT2 Inline Cleaner requires supplying air at the appropriate pressure to the tensioner air bags. Refer to Table II for recommended air pressure.
2. If using the Air Tensioner Air Regulator Kit, connect the plant air line to the lockable ball valve on the outside of the enclosure. Turn on the air supply and the ball valve to pressurize the tensioner. The cleaner will automatically rise and the blades will contact the belt.
3. Adjust the pressure to the required level by unlocking and adjusting the regulator inside the regulator kit. The regulator is self-relieving so the pressure will stabilize. (It is advisable to wait a short while after each adjustment to allow excess pressure to bleed.)
4. Once the correct pressure has been achieved, relock the regulator and close the lid on the enclosure.

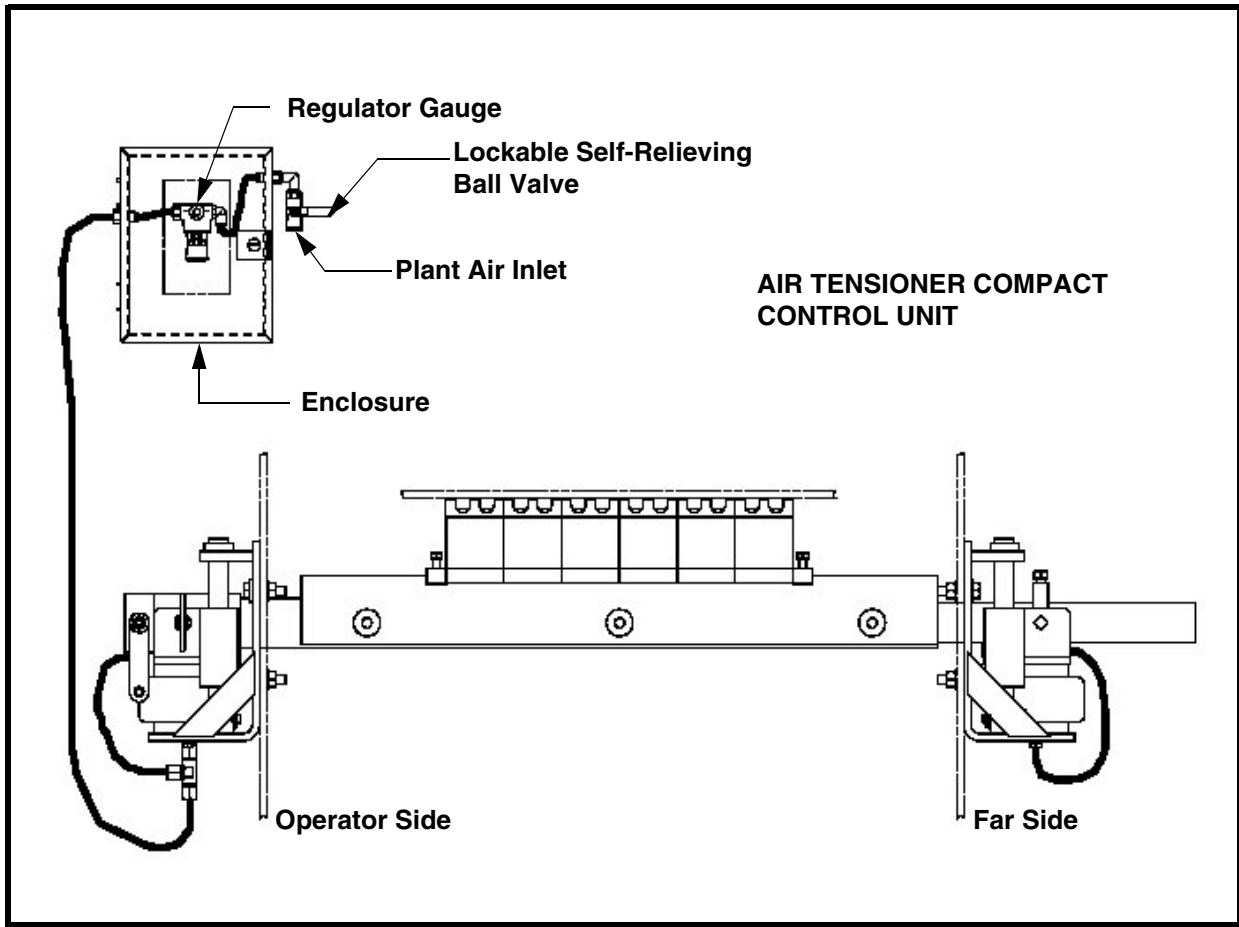

Figure 5. Air Tensioner Operation

After Installing Belt Cleaner

IMPORTANT

Read entire section before beginning work.

1. After belt cleaner and tensioner are installed, measure from pulley shaft to mainframe on both operator side and far side to make sure mainframe is parallel to pulley.
2. Measure from center point of pulley to outside edge of first and last blade to make sure blades are centered on belt.
3. Make sure cleaner is not changing belt line (Figure 6a). If it is, install belt support ahead of blade-to-belt contact point (Figure 6b).

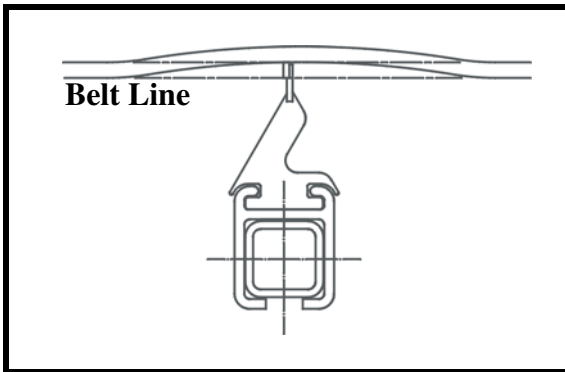

Figure 6a. Cleaner Changing Belt Line

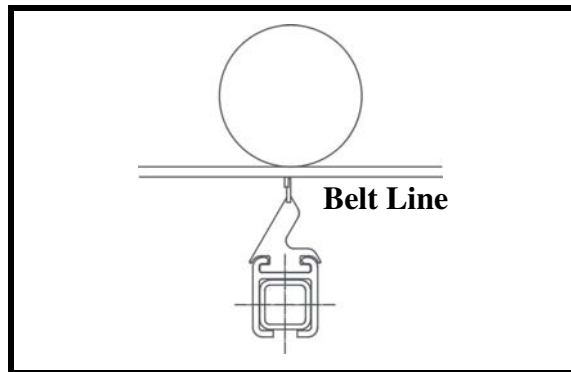

Figure 6b. Cleaner with Belt Support

4. Thoroughly wipe outside chute walls clean above tensioners on both sides of chute. Place Conveyor Products Warning Labels (P/N 23395) on chute walls or where they will be visible to belt cleaner operator.

WARNING

Failure to remove tools from installation area and conveyor belt before turning on energy source can cause serious injury to personnel and damage to belt.

5. Remove all tools and fire retardant cover from installation area and conveyor belt.

DANGER

Do not touch or go near conveyor belt or conveyor accessories when conveyor belt is running. Body or clothing can get caught and pull body into conveyor belt, causing severe injury or death.

6. Turn on conveyor belt for 1 hour.

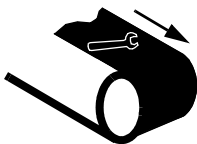



⚠ WARNING

Before adjusting belt cleaner, turn off and lock out/tag out energy source to conveyor belt and conveyor accessories.

7. After 1 hour of operation, turn off and lock out/tag out energy source according to ANSI standards (see “References”).
8. Make sure all fasteners are tight. Tighten if necessary.
9. Inspect belt cleaner for the following:
 - Wear. (A small amount of “break-in” wear may be found.)
 - Material buildup. (No material between blades and return side of conveyor belt should be found.)
10. If wear, material buildup, or some other problem exists, see “Troubleshooting/Installation Checklist.”

NOTE

Maintenance inspection should be performed no less than weekly. Your application may require more frequent maintenance inspections.

IMPORTANT

Read entire section before beginning work.

⚠ WARNING

Before servicing belt cleaner, turn off and lock out/tag out energy source to conveyor belt and conveyor accessories. Turn off and lock out/tag out energy source according to ANSI standards (see “References”).



Routine Inspection/Tension

1. Inspect the condition of the cleaner. Open the inspection door (if fitted) and observe the condition and action of the blades and cleaner.
2. If necessary, remove any material buildup from the blades or mainframe.

⚠ WARNING

Do not reach into the chute while the conveyor is running.

3. If necessary, adjust the cleaner tension. Refer to appropriate section for tensioner used.
4. Make sure all fasteners are tight. Tighten if necessary.
5. Check blades for wear and replace if necessary.
6. Wipe warning labels clean. If labels are not readable, contact Martin Engineering or a representative for replacements.



Blade Servicing

⚠ WARNING

Before servicing belt cleaner, turn off and lock out/tag out energy source to conveyor belt and conveyor accessories. Turn off and lock out/tag out energy source according to ANSI standards (see “References”).

1. Undo tensioner and visually inspect blades.
 - a. If blades are clean and not excessively worn, re-tension cleaner.
 - b. If material buildup is still present or blades are worn excessively, proceed.
2. When fully retracted, simply remove the retaining pin securing the blade cartridge to the operator end of the mainframe. Grasp the handle and pull the blade cartridge off the mainframe and away from the mount bracket. Completely remove the blade cartridge from the mainframe and place it in a suitable position for maintenance work to be carried out.

3. Clean and inspect the blades. If blades are excessively worn, replace with new blades. Remove the blades from the cartridge by removing one of the end stops. Slide the blades out of the cartridge and replace by sliding in new blades. Ensure the blades face in the correct direction. Re-fit the end stop. These prevent belt damage by supporting the belt at the edge of the cleaning blades. If removing both end stops, first mark their position in the cartridge to ensure correct positioning of blades on re-assembly.
4. Re-install blade cartridge onto the cleaner mainframe and re-fit the securing pin at the operator side. Re-tension the cleaner.
5. Remove equipment from service if there is any indication it is not functioning properly. Call Martin Engineering or representative for assistance. Do NOT return equipment to operation until the cause of the problem has been identified and corrected.
6. Wipe all labels clean. If labels are not readable, contact Martin Engineering or representative for replacements.

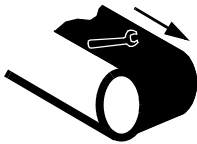

⚠ WARNING

Failure to remove tools from maintenance area and conveyor belt before turning on energy source can cause serious injury to personnel and damage to belt.

7. Remove all tools from maintenance area.

⚠ DANGER

Do not touch or go near conveyor belt or conveyor accessories when conveyor belt is running. Body or clothing can get caught and pulled into conveyor belt, causing severe injury or death.



8. Start conveyor belt.
9. Observe cleaner action and blade effectiveness.

Troubleshooting/Installation Checklist

Troubleshooting

If you are experiencing problems with belt cleaner, see below:

Symptom	Corrective Action
Blades pop out of track.	Tension is set too high. Reduce pressure or tension.
High blade wear rate.	Tension is set too high. Reduce pressure or tension.
Insufficient cleaning and carryback.	<ul style="list-style-type: none"> Tension is set too low or too high. Increase or decrease pressure or tension. Check blades for excessive wear and replace if necessary.
Blades vibrate.	<ul style="list-style-type: none"> Incorrect installation angle. Check installation, ensuring cleaner mount is perpendicular to belt. Belt deflected upward on tensioning of cleaner. Install an idler roller over the belt near the belt contact point. Belt vibration being transferred to cleaner. Install an idler roller over the belt near the blade contact point.
Mainframe bent.	<ul style="list-style-type: none"> Mainframe undersized. Stiffened mainframe required. Contact Martin Engineering for assistance. Excessive tension. Relax blade tension to maximum tension recommended in installation instructions. Increase frequency of inspection and service once a week. A small amount of deflection is considered normal. Contact Martin Engineering if excessive deflection occurs.

NOTE

Conveyor equipment such as conveyor belt cleaners are subject to a wide variety of bulk materials characteristics and often have to perform under extreme operating or environmental conditions. It is not possible to predict all circumstances that may require troubleshooting. Contact Martin Engineering or a representative if you are experiencing problems other than those listed in the “Troubleshooting” chart above. Do not return the equipment to operation until the problem has been identified and corrected.

Installation checklist

If after taking corrective actions suggested under “Troubleshooting” you are still experiencing problems, check for the following:

Installation Checklist
- Mainframe is parallel to pulley.
- Blades are perpendicular to belt.
- Blades are centered on belt.

Part Numbers

This section provides product names and corresponding part numbers for Martin® DT2 Inline Cleaner and related equipment. Please reference part numbers when ordering parts:

Martin® DT2 Inline Cleaner

Martin® DT2 Inline Cleaner with Air Tensioner:
P/N DT2S-XXXXXXXXXA.

Martin® DT2 Inline Cleaner with Spring Tensioner:
P/N DT2S-XXXXXXXXXS.

Martin® DT2 Inline Cleaner Cartridge:
P/N DT2SC-XXXXXXXXXX.

NOMENCLATURE

DT2S-XX X XX XX X X

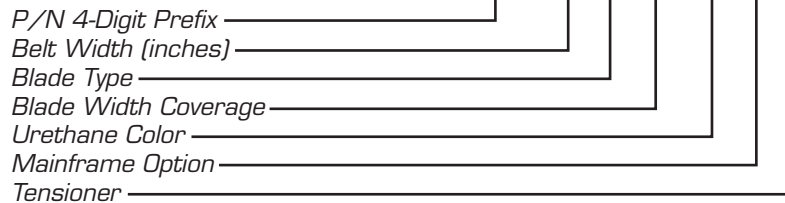

Blade Type

- T:** Tungsten Carbide Reversing Blade
- S:** Stainless Steel Reversing Blade
- A:** INLINE Tungsten Carbide Blade
- U:** Urethane Reversing Blade

Mainframe

- P:** Standard Duty
- S:** 316 Stainless Steel

Urethane Color

- BR:** Brown
- GR:** Green
- OR:** Orange

Tensioner Type

- A:** Air Tensioner
- S:** Spring Tensioner

Miscellaneous

Reversing Hanger Mount Weldment (Pair): P/N 33288.

Reversing Hanger Mount Weldment: P/N 33282.

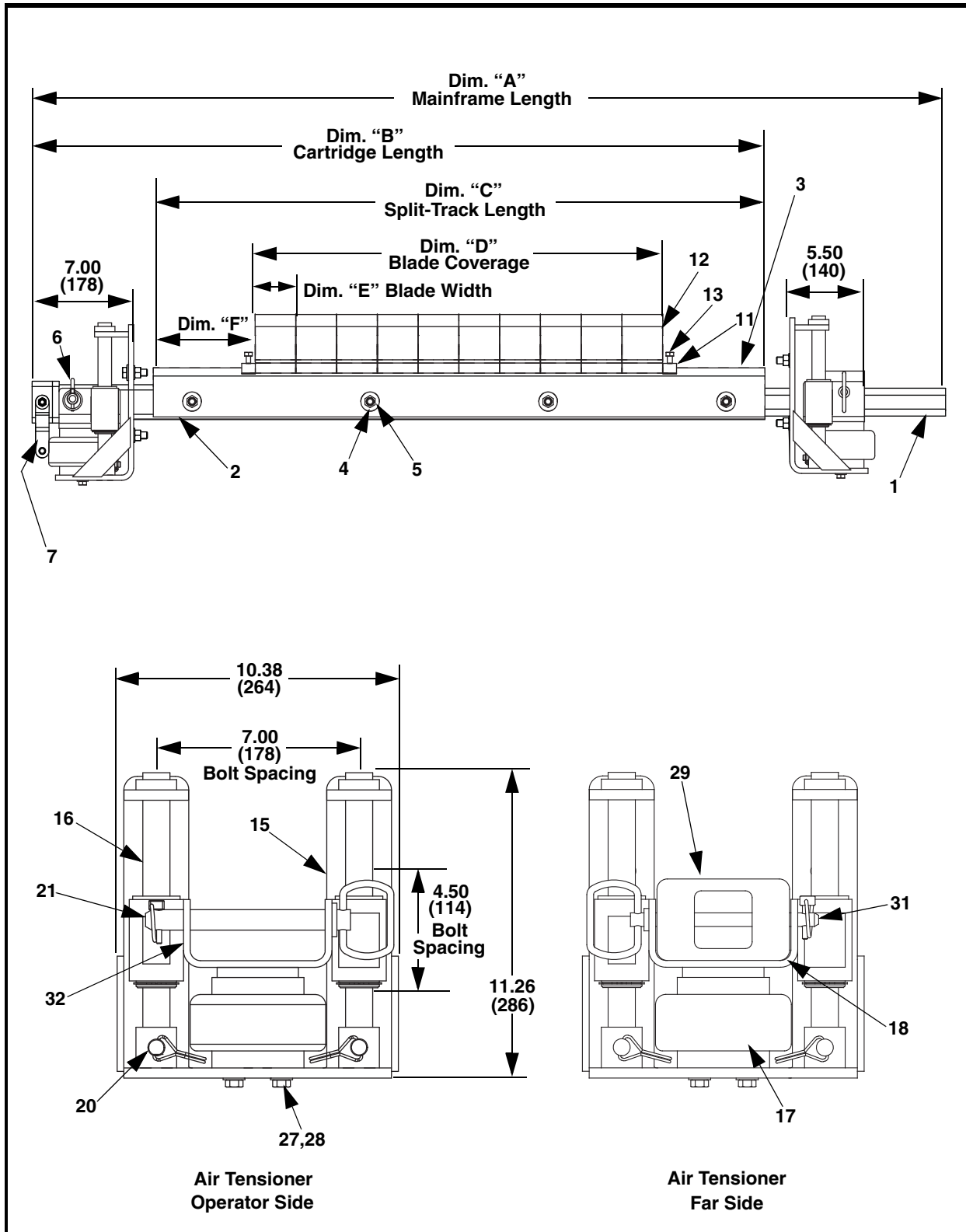

Figure 7a. Martin® DT2 Inline Cleaner with Inline Blades and Air Tensioner, P/N DT2S-XXXXXXXXA

Item	Description	Part No.	Qty
1	Inline Frame Mandrel	Table III	1
2	Inline Split-Track Mainframe Weldment	Table III	1
3	Split Frame	Table III	1
4	Washer, Flat 1/2 Wide	Table III	Table III
5	Nut, Hex Elastic Lock 1/2-13NC	Table III	Table III
6	End Cap	37705	1
7	Handle Weldment	Table III	1
8	Washer, Flat 3/8 Wide	Table III	2
9	Screw, HHC 3/8-16NC X 4-1/2	Table III	1
10	Nut, Hex Elastic Lock 3/8-16NC	Table III	1
11	End Stop	Table III	2
12	Blade	Table III	Table III
13	Screw, HHC 3/8-16NC X 2	Table III	2
14	Inline/Reversing Air Tensioner	37707-A	1
15	Tensioner Mount Plate Weldment	37701	2
16	Tensioner Guide Rod Weldment	37702	4
17	Tensioner Air Bag	30587	2
18	Tensioner Slide Bracket	37703-OSA	1
19 (NS)	Tensioner UHMW Sleeve	37704	4
20	Tensioner Pin, Quick Release 3/8 x 1-3/4 ZP	37126	4
21	Tensioner Pin, Hitch 3/4 x 6-1/4	38073	1
22 (NS)	Tensioner Washer, Flat 1/2 Thick SS	19126	8
23 (NS)	Tensioner Screw, HHC 1/2-13NC X 1-1/2 SS	22766	8
24 (NS)	Tensioner Washer, Compression 1/2 SS	24310	8
25 (NS)	Tensioner Nut, Hex 1/2-13NC SS	17151	8
26	Tensioner Screw, SHC 3/8-16NC X 3/4 ZP	36510	4
27	Tensioner Washer, Compression 3/8	11747	4
28	Tensioner Screw, HHC 3/8-16NC X 1 ZP	11746-02	4
29	Tensioner Far Side End Cap	37705-F	1
30	Tensioner Pin, Hitch 1/2 x 5-3/4	35876	1
31	Tensioner Slide Bracket	37703-A	1
32 (NS)	Tensioner Label, Pinch Point Warning	30528	2
33 (NS)	Tensioner Label, for Reversing Tensioner	35949	2
34 (NS)	Label, Conveyor Products Warning (2 ea. Tens. & Assy.)	23395	4
35 (NS)	Label, Martin® Products (Tens.)	32238	2
36 (NS)	Label, Martin® Products (Assy.)	38048	2
37 (NS)	Manual, Operators	M3687	1
38 (NS)	Tensioner External Retaining Ring	38301	4

Figure 7b. Martin® DT2 Inline Cleaner with Air Tensioner, P/N DT2S-XXXXXXXXA

NS = Not Shown

Table III. Martin® DT2 Inline Cleaner with Air Tensioner

Part No. Std-Duty Mainframe	Dim "A"	Dim "B"	Dim "C"	Dim "D"	Dim. "F" Blade Type	
					T, S, U	A
DT2S-18X12XXXX	49.50 (1257)	36.16 (918)	27.00 (686)	12.00 (305)	6.38 (162)	6.50 (165)
DT2S-18X18XXXX	49.50 (1257)	36.16 (918)	27.00 (686)	18.00 (457)	3.38 (86)	3.50 (89)
DT2S-24X18XXXX	55.50 (1410)	42.16 (1071)	33.00 (838)	18.00 (457)	6.38 (162)	6.50 (165)
DT2S-24X24XXXX	55.50 (1410)	42.16 (1071)	33.00 (838)	24.00 (610)	3.38 (86)	3.50 (89)
DT2S-30X24XXXX	61.50 (1562)	48.16 (1223)	39.00 (991)	24.00 (610)	6.38 (162)	6.50 (165)
DT2S-30X30XXXX	61.50 (1562)	48.16 (1223)	39.00 (991)	30.00 (762)	3.38 (86)	3.50 (89)
DT2S-36X30XXXX	67.50 (1715)	54.16 (1376)	45.00 (1143)	30.00 (762)	6.38 (162)	6.50 (165)
DT2S-36X36XXXX	67.50 (1715)	54.16 (1376)	45.00 (1143)	36.00 (914)	3.38 (86)	3.50 (89)
DT2S-42X36XXXX	73.50 (1867)	60.16 (1528)	51.00 (1295)	36.00 (914)	6.38 (162)	6.50 (165)
DT2S-42X42XXXX	73.50 (1867)	60.16 (1528)	51.00 (1295)	42.00 (967)	3.38 (86)	3.50 (89)
DT2S-48X42XXXX	79.50 (2019)	66.16 (1680)	57.00 (1448)	42.00 (967)	6.38 (162)	6.50 (165)
DT2S-48X48XXXX	79.50 (2019)	66.16 (1680)	57.00 (1448)	48.00 (1219)	3.38 (86)	3.50 (89)
DT2S-54X48XXXX	85.50 (2172)	72.16 (1833)	63.00 (1600)	48.00 (1219)	6.38 (162)	6.50 (165)
DT2S-54X54XXXX	85.50 (2172)	72.16 (1833)	63.00 (1600)	54.00 (1372)	3.38 (86)	3.50 (89)
DT2S-60X54XXXX	91.50 (2324)	78.16 (1985)	69.00 (1753)	54.00 (1372)	6.38 (162)	6.50 (165)
DT2S-60X60XXXX	91.50 (2324)	78.16 (1985)	69.00 (1753)	60.00 (1524)	3.38 (86)	3.50 (89)
DT2S-66X60XXXX	97.50 (2477)	84.16 (2138)	75.00 (1905)	60.00 (1524)	6.38 (162)	6.50 (165)
DT2S-66X66XXXX	97.50 (2477)	84.16 (2138)	75.00 (1905)	66.00 (1676)	3.38 (86)	3.50 (89)
DT2S-72X66XXXX	103.50 (2629)	90.16 (2290)	81.00 (2057)	66.00 (1676)	6.38 (162)	6.50 (165)
DT2S-84X78XXXX	115.50 (2934)	102.16 (2595)	93.00 (2362)	78.00 (1981)	6.38 (162)	6.50 (165)
DT2S-96X90XXXX	127.50 (3239)	114.16 (2900)	105.00 (2667)	90.00 (2286)	6.38 (162)	6.50 (165)
DT2S-120X114XXXX	151.50 (3848)	138.16 (3509)	123.00 (3124)	114.00 (2896)	6.38 (162)	6.50 (165)

Part No. Std-Duty Mainframe	Item 1 P/N	Item 2 P/N	Item 3 P/N	Qty Items 4, 5	Qty Item 12	
					T, S, U	A
DT2S-18X12XXXX	37714-18	37717-18	34423-30	2	2	4
DT2S-18X18XXXX	37714-18	37717-18	34423-30	2	3	6
DT2S-24X18XXXX	37714-24	37717-24	34423-36	3	3	6
DT2S-24X24XXXX	37714-24	37717-24	34423-36	3	4	8
DT2S-30X24XXXX	37714-30	37717-30	34423-42	3	4	8
DT2S-30X30XXXX	37714-30	37717-30	34423-42	3	5	10
DT2S-36X30XXXX	37714-36	37717-36	34423-48	4	5	10
DT2S-36X36XXXX	37714-36	37717-36	34423-48	4	6	12
DT2S-42X36XXXX	37714-42	37717-42	34423-54	4	6	12
DT2S-42X42XXXX	37714-42	37717-42	34423-54	4	7	14
DT2S-48X42XXXX	37714-48	37717-48	34423-60	5	7	14
DT2S-48X48XXXX	37714-48	37717-48	34423-60	5	8	16
DT2S-54X48XXXX	37714-54	37717-54	34423-66	5	8	16
DT2S-54X54XXXX	37714-54	37717-54	34423-66	5	9	18
DT2S-60X54XXXX	37714-60	37717-60	34423-72	5	9	18
DT2S-60X60XXXX	37714-60	37717-60	34423-72	5	10	20
DT2S-66X60XXXX	37714-66	37717-66	34423-78	6	10	20
DT2S-66X66XXXX	37714-66	37717-66	34423-78	6	11	22
DT2S-72X66XXXX	37714-72	37717-72	34423-84	6	11	22
DT2S-84X78XXXX	37714-84	37717-84	34423-96	7	13	26
DT2S-96X90XXXX	37714-96	37717-96	34423-108	8	15	30
DT2S-120X114XXXX	37714-120	37717-120	34423-126	10	19	38

Part No. 316 SS Mainframe	Item 1 P/N	Item 2 P/N	Item 3 P/N
DT2S-18X12XXSX	37714-18-316SS	37717-18-316SS	34423-030N
DT2S-18X18XXSX	37714-18-316SS	37717-18-316SS	34423-030N
DT2S-24X18XXSX	37714-24-316SS	37717-24-316SS	34423-036N
DT2S-24X24XXSX	37714-24-316SS	37717-24-316SS	34423-036N
DT2S-30X24XXSX	37714-30-316SS	37717-30-316SS	34423-042N
DT2S-30X30XXSX	37714-30-316SS	37717-30-316SS	34423-042N
DT2S-36X30XXSX	37714-36-316SS	37717-36-316SS	34423-048N
DT2S-36X36XXSX	37714-36-316SS	37717-36-316SS	34423-048N
DT2S-42X36XXSX	37714-42-316SS	37717-42-316SS	34423-054N
DT2S-42X42XXSX	37714-42-316SS	37717-42-316SS	34423-054N
DT2S-48X42XXSX	37714-48-316SS	37717-48-316SS	34423-060N
DT2S-48X48XXSX	37714-48-316SS	37717-48-316SS	34423-060N
DT2S-54X48XXSX	37714-54-316SS	37717-54-316SS	34423-066N

Part Numbers

Part No. 316 SS Mainframe	Item 1 P/N	Item 2 P/N	Item 3 P/N
DT2S-54X54XXSX	37714-54-316SS	37717-54-316SS	34423-066N
DT2S-60X54XXSX	37714-60-316SS	37717-60-316SS	34423-072N
DT2S-60X60XXSX	37714-60-316SS	37717-60-316SS	34423-072N
DT2S-66X60XXSX	37714-66-316SS	37717-66-316SS	34423-078N
DT2S-66X66XXSX	37714-66-316SS	37717-66-316SS	34423-078N
DT2S-72X66XXSX	37714-72-316SS	37717-72-316SS	34423-084N
DT2S-84X78XXSX	37714-84-316SS	37717-84-316SS	34423-096N
DT2S-96X90XXSX	37714-96-316SS	37717-96-316SS	34423-108N

Part No.	Mainframe Type	Item 4 P/N	Item 5 P/N	Item 7 P/N	Item 8 P/N
DT2S-XXXXXXXXPX	Std Duty	17328	18577	36313	18007
DT2S-XXXXXXXXSX	316 SS	35913	SP03938-02	36313-316SS	37471

Part No.	Mainframe Type	Item 9 P/N	Item 10 P/N	Item 13 P/N
DT2S-XXXXXXXXPX	Std Duty	34082	14201	37036
DT2S-XXXXXXXXSX	316 SS	37764	SP03938-12	37763

Blade Part No.	Blade Type	Item 11 P/N	Item 12 P/N	Dim "E"
DT2S-XXAXXXXXXX	INLINE TC	37015	36316-TXX	3.00 (76)
DT2S-XXAXXXXXSX	INLINE TC	37015-N	36316-TXX	3.00 (76)
DT2S-XXTXXXXXX	REVERSING TC	37015	31104-TXX	6.00 (152)
DT2S-XXTXXXXSX	REVERSING TC	37015-N	31104-TXX	6.00 (152)
DT2S-XXSXXXXXX	REVERSING SS	37015	31104-SXX	6.00 (152)
DT2S-XXSXXXXSX	REVERSING SS	37015-N	31104-SXX	6.00 (152)
DT2S-XXUXXXXXX	REVERSING URETHANE	37015	31104-UXX	6.00 (152)
DT2S-XXUXXXXSX	REVERSING URETHANE	37015-N	31104-UXX	6.00 (152)

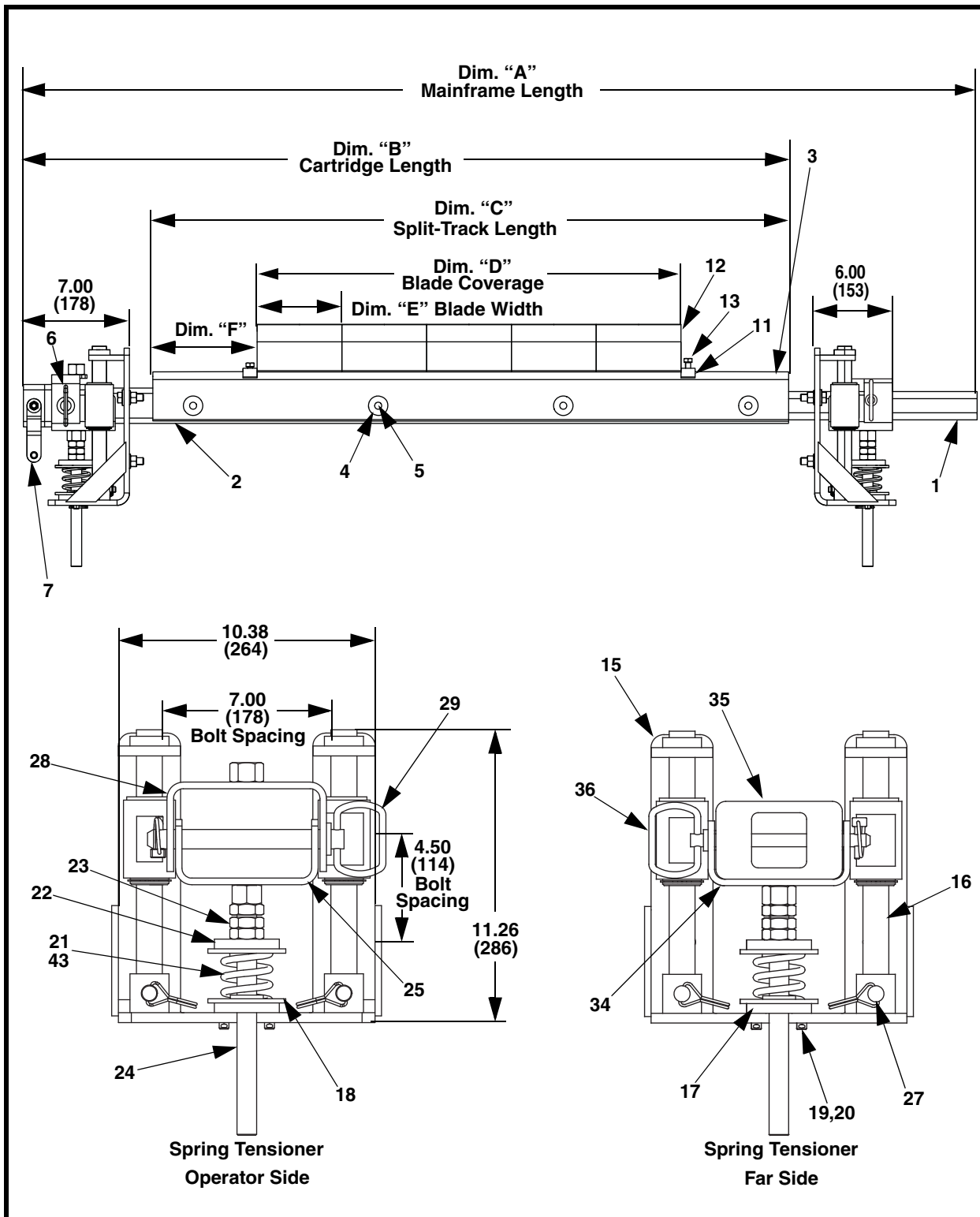

Figure 8a. Martin® DT2 In-line Cleaner with In-line Blades and Spring Tensioner, P/N DT2S-XXXXXXXXS

Part Numbers

Item	Description	Part No.	Qty
1	Inline Frame Mandrel	Table IV	1
2	Inline Split-Track Mainframe Weldment	Table IV	1
3	Split Frame	Table IV	1
4	Washer, Flat 1/2 Wide	Table IV	Table IV
5	Nut, Hex Elastic Lock 1/2-13NC	Table IV	Table IV
6	End Cap	37705	1
7	Handle Weldment	Table IV	1
8	Washer, Flat 3/8 Wide	Table IV	2
9	Screw, HHC 3/8-16NC X 4-1/2	Table IV	1
10	Nut, Hex Elastic Lock 3/8-16NC	Table IV	1
11	End Stop	Table IV	2
12	Blade	Table IV	Table IV
13	Screw, HHC 3/8-16NC X 2	Table IV	2
14	Inline/Reversing Spring Tensioner	37707	1
15	Tensioner Mount Plate Weldment	37701	2
16	Tensioner Guide Rod Weldment	37702	4
17	Tensioner Spring, Retainer	33594	2
18	Tensioner Washer, Flat 1-1/4 Wide ZP	33951	4
19	Tensioner Pin, Clevis 3/8 X 7/8 ZP	33949	4
20	Tensioner Pin, Cotter 1/8 X 1 Ext. Prong ZP	16578	4
21	Tensioner Spring, ø2 X 1-3/4 Long	33602	2
22	Tensioner Spring, Retainer	33594-01	2
23	Tensioner Nut, Hex Jam 3/4-6 ACME ZP	38219	6
24	Tensioner Threaded Rod 7.50 Long	37706	2
25	Tensioner Slide Bracket	37703-0S	1
26 (NS)	Tensioner UHMW Sleeve	37704	4
27	Tensioner Pin Wire Lock 3/8 x 1-3/4	37126	4
28	Tensioner, Top Mount	37703-OSTOP	1
29	Tensioner Pin, Hitch 3/4 x 6-1/4	38073	1
30 (NS)	Tensioner Washer, Flat 1/2 Thick SS	19126	8
31 (NS)	Tensioner Screw, HHC 1/2-13NC X 1-1/2 SS	22766	8
32 (NS)	Tensioner Washer, Compression 1/2 SS	24310	8
33 (NS)	Tensioner Nut, Hex 1/2-13NC SS	17151	8
34	Tensioner Slide Bracket	37703	1
35	Tensioner Far Side End Cap	37705-F	1
36	Tensioner Pin Hitch 1/2 x 5-3/4	35876	1
37 (NS)	Tensioner Label, Pinch Point Warning	30528	2
38 (NS)	Tensioner Label, for Reversing Tensioner	35949	2
39 (NS)	Label, Conveyor Products Warning (2 ea. Tens. & Assy.)	23395	4

Item	Description	Part No.	Qty
40 (NS)	Label, Martin® Products (Tens.)	32238	2
41 (NS)	Label, Martin® Products (Assy.)	38048	2
42 (NS)	Manual, Operators	M3687	1
43*	Tensioner Spring, Die 2.00 Long	38026	2
44*	Tensioner Washer, Flat 3/4 ZP	20164	2
45 (NS)	Tensioner External Retaining Ring	38301	4

**Figure 8b. Martin® DT2 Inline Cleaner with Spring Tensioner,
P/N DT2S-XXXXXXXXS**

NS = Not Shown

*Shipped loose. Use on belt widths 54.00 (1400) and larger.

Table IV. Martin® DT2 Inline Cleaner with Spring Tensioner

Part No. Std-Duty Mainframe	Dim "A"	Dim "B"	Dim "C"	Dim "D"	Dim. "F" Blade Type	
					T, S, U	A
DT2S-18X12XXXX	49.50 (1257)	36.16 (918)	27.00 (686)	12.00 (305)	6.38 (162)	6.50 (165)
DT2S-18X18XXXX	49.50 (1257)	36.16 (918)	27.00 (686)	18.00 (457)	3.38 (86)	3.50 (89)
DT2S-24X18XXXX	55.50 (1410)	42.16 (1071)	33.00 (838)	18.00 (457)	6.38 (162)	6.50 (165)
DT2S-24X24XXXX	55.50 (1410)	42.16 (1071)	33.00 (838)	24.00 (610)	3.38 (86)	3.50 (89)
DT2S-30X24XXXX	61.50 (1562)	48.16 (1223)	39.00 (991)	24.00 (610)	6.38 (162)	6.50 (165)
DT2S-30X30XXXX	61.50 (1562)	48.16 (1223)	39.00 (991)	30.00 (762)	3.38 (86)	3.50 (89)
DT2S-36X30XXXX	67.50 (1715)	54.16 (1376)	45.00 (1143)	30.00 (762)	6.38 (162)	6.50 (165)
DT2S-36X36XXXX	67.50 (1715)	54.16 (1376)	45.00 (1143)	36.00 (914)	3.38 (86)	3.50 (89)
DT2S-42X36XXXX	73.50 (1867)	60.16 (1528)	51.00 (1295)	36.00 (914)	6.38 (162)	6.50 (165)
DT2S-42X42XXXX	73.50 (1867)	60.16 (1528)	51.00 (1295)	42.00 (967)	3.38 (86)	3.50 (89)
DT2S-48X42XXXX	79.50 (2019)	66.16 (1680)	57.00 (1448)	42.00 (967)	6.38 (162)	6.50 (165)
DT2S-48X48XXXX	79.50 (2019)	66.16 (1680)	57.00 (1448)	48.00 (1219)	3.38 (86)	3.50 (89)
DT2S-54X48XXXX	85.50 (2172)	72.16 (1833)	63.00 (1600)	48.00 (1219)	6.38 (162)	6.50 (165)
DT2S-54X54XXXX	85.50 (2172)	72.16 (1833)	63.00 (1600)	54.00 (1372)	3.38 (86)	3.50 (89)
DT2S-60X54XXXX	91.50 (2324)	78.16 (1985)	69.00 (1753)	54.00 (1372)	6.38 (162)	6.50 (165)
DT2S-60X60XXXX	91.50 (2324)	78.16 (1985)	69.00 (1753)	60.00 (1524)	3.38 (86)	3.50 (89)
DT2S-66X60XXXX	97.50 (2477)	84.16 (2138)	75.00 (1905)	60.00 (1524)	6.38 (162)	6.50 (165)
DT2S-66X66XXXX	97.50 (2477)	84.16 (2138)	75.00 (1905)	66.00 (1676)	3.38 (86)	3.50 (89)
DT2S-72X66XXXX	103.50 (2629)	90.16 (2290)	81.00 (2057)	66.00 (1676)	6.38 (162)	6.50 (165)
DT2S-84X78XXXX	115.50 (2934)	102.16 (2595)	93.00 (2362)	78.00 (1981)	6.38 (162)	6.50 (165)
DT2S-96X90XXXX	127.50 (3239)	114.16 (2900)	105.00 (2667)	90.00 (2286)	6.38 (162)	6.50 (165)
DT2S-120X114XXXX	151.50 (3848)	138.16 (3509)	123.00 (3124)	114.00 (2896)	6.38 (162)	6.50 (165)

Part Numbers

Part No. Std-Duty Mainframe	Item 1 P/N	Item 2 P/N	Item 3 P/N	Qty Items 4, 5	Qty Item 12	
					T, S, U	A
DT2S-18X12XXXX	37714-18	37717-18	34423-30	2	2	4
DT2S-18X18XXXX	37714-18	37717-18	34423-30	2	3	6
DT2S-24X18XXXX	37714-24	37717-24	34423-36	3	3	6
DT2S-24X24XXXX	37714-24	37717-24	34423-36	3	4	8
DT2S-30X24XXXX	37714-30	37717-30	34423-42	3	4	8
DT2S-30X30XXXX	37714-30	37717-30	34423-42	3	5	10
DT2S-36X30XXXX	37714-36	37717-36	34423-48	4	5	10
DT2S-36X36XXXX	37714-36	37717-36	34423-48	4	6	12
DT2S-42X36XXXX	37714-42	37717-42	34423-54	4	6	12
DT2S-42X42XXXX	37714-42	37717-42	34423-54	4	7	14
DT2S-48X42XXXX	37714-48	37717-48	34423-60	5	7	14
DT2S-48X48XXXX	37714-48	37717-48	34423-60	5	8	16
DT2S-54X48XXXX	37714-54	37717-54	34423-66	5	8	16
DT2S-54X54XXXX	37714-54	37717-54	34423-66	5	9	18
DT2S-60X54XXXX	37714-60	37717-60	34423-72	5	9	18
DT2S-60X60XXXX	37714-60	37717-60	34423-72	5	10	20
DT2S-66X60XXXX	37714-66	37717-66	34423-78	6	10	20
DT2S-66X66XXXX	37714-66	37717-66	34423-78	6	11	22
DT2S-72X66XXXX	37714-72	37717-72	34423-84	6	11	22
DT2S-84X78XXXX	37714-84	37717-84	34423-96	7	13	26
DT2S-96X90XXXX	37714-96	37717-96	34423-108	8	15	30
DT2S-120X114XXXX	37714-120	37717-120	34423-126	10	19	38

Part No. 316 SS Mainframe	Item 1 P/N	Item 2 P/N	Item 3 P/N
DT2S-18X12XXSX	37714-18-316SS	37717-18-316SS	34423-030N
DT2S-18X18XXSX	37714-18-316SS	37717-18-316SS	34423-030N
DT2S-24X18XXSX	37714-24-316SS	37717-24-316SS	34423-036N
DT2S-24X24XXSX	37714-24-316SS	37717-24-316SS	34423-036N
DT2S-30X24XXSX	37714-30-316SS	37717-30-316SS	34423-042N
DT2S-30X30XXSX	37714-30-316SS	37717-30-316SS	34423-042N
DT2S-36X30XXSX	37714-36-316SS	37717-36-316SS	34423-048N
DT2S-36X36XXSX	37714-36-316SS	37717-36-316SS	34423-048N
DT2S-42X36XXSX	37714-42-316SS	37717-42-316SS	34423-054N
DT2S-42X42XXSX	37714-42-316SS	37717-42-316SS	34423-054N
DT2S-48X42XXSX	37714-48-316SS	37717-48-316SS	34423-060N
DT2S-48X48XXSX	37714-48-316SS	37717-48-316SS	34423-060N
DT2S-54X48XXSX	37714-54-316SS	37717-54-316SS	34423-066N

Part No. 316 SS Mainframe	Item 1 P/N	Item 2 P/N	Item 3 P/N
DT2S-54X54XXSX	37714-54-316SS	37717-54-316SS	34423-066N
DT2S-60X54XXSX	37714-60-316SS	37717-60-316SS	34423-072N
DT2S-60X60XXSX	37714-60-316SS	37717-60-316SS	34423-072N
DT2S-66X60XXSX	37714-66-316SS	37717-66-316SS	34423-078N
DT2S-66X66XXSX	37714-66-316SS	37717-66-316SS	34423-078N
DT2S-72X66XXSX	37714-72-316SS	37717-72-316SS	34423-084N
DT2S-84X78XXSX	37714-84-316SS	37717-84-316SS	34423-096N
DT2S-96X90XXSX	37714-96-316SS	37717-96-316SS	34423-108N

Part No.	Mainframe Type	Item 4 P/N	Item 5 P/N	Item 7 P/N	Item 8 P/N
DT2S-XXXXXXXPX	Std Duty	17328	18577	36313	18007
DT2S-XXXXXXXSX	316 SS	35913	SP03938-02	36313-316SS	37471

Part No.	Mainframe Type	Item 9 P/N	Item 10 P/N	Item 13 P/N
DT2S-XXXXXXXPX	Std Duty	34082	14201	37036
DT2S-XXXXXXXSX	316 SS	37764	SP03938-12	37763

Blade Part No.	Blade Type	Item 11 P/N	Item 12 P/N	Dim "E"
DT2S-XXAXXXXXX	INLINE TC	37015	36316-TXX	3.00 (76)
DT2S-XXAXXXXXSX	INLINE TC	37015-N	36316-TXX	3.00 (76)
DT2S-XXTXXXXXX	REVERSING TC	37015	31104-TXX	6.00 (152)
DT2S-XXTXXXXXSX	REVERSING TC	37015-N	31104-TXX	6.00 (152)
DT2S-XXSXXXXXX	REVERSING SS	37015	31104-SXX	6.00 (152)
DT2S-XXSXXXXXSX	REVERSING SS	37015-N	31104-SXX	6.00 (152)
DT2S-XXUXXXXXX	REVERSING URETHANE	37015	31104-UXX	6.00 (152)
DT2S-XXUXXXXXSX	REVERSING URETHANE	37015-N	31104-UXX	6.00 (152)

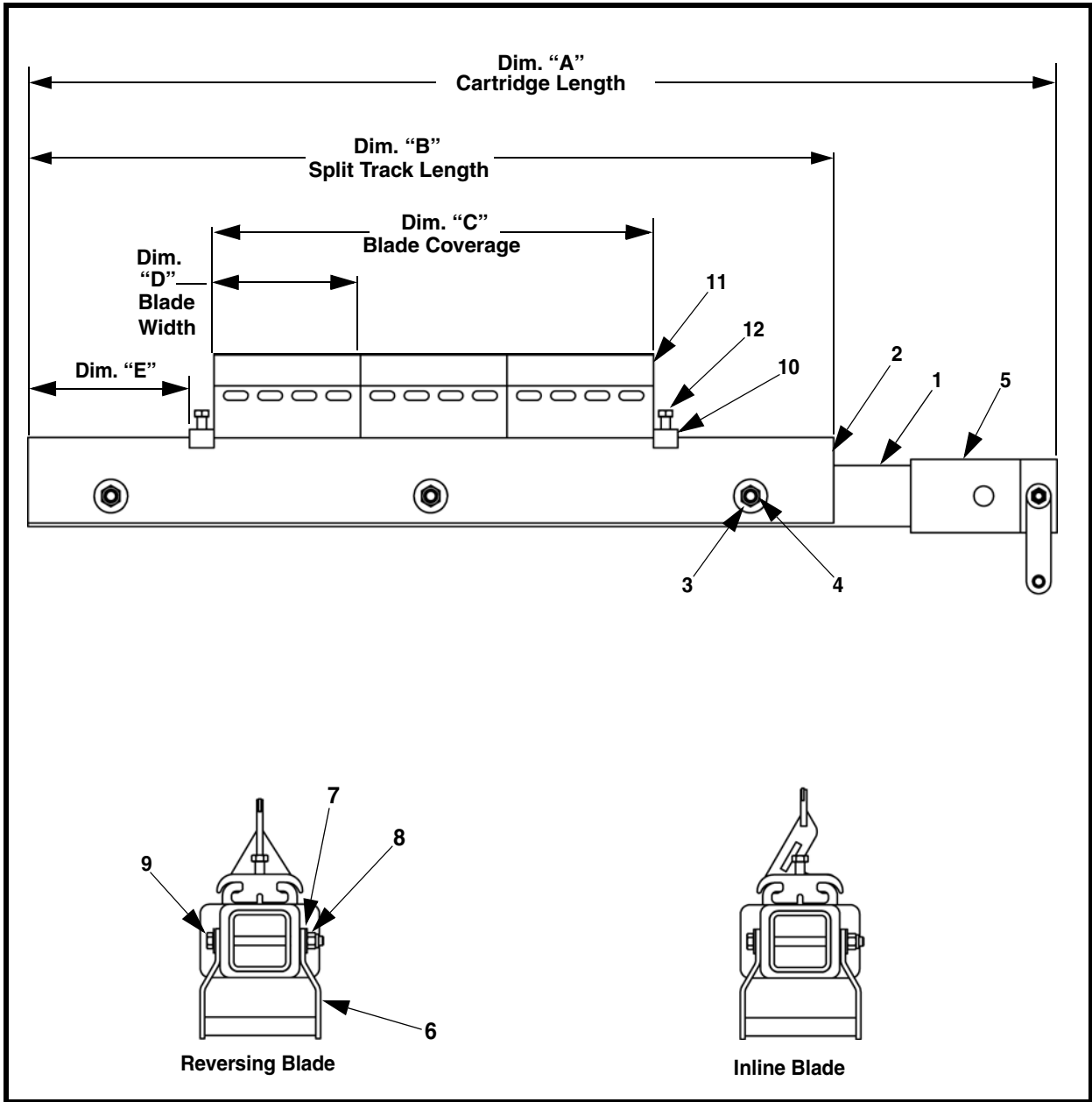

Figure 9a. Martin[®] DT2 Inline Cleaner Cartridge, P/N DT2SC-XXXXXXXXXX

Item	Description	Part No.	Qty
1	Inline Split-Track Mainframe Weldment	Table V	1
2	Split Frame	Table V	1
3	Washer, Flat 1/2 Wide	Table V	Table V
4	Nut, Hex Elastic Lock 1/2-13NC	Table V	Table V
5	End Cap	37705	1
6	Handle Weldment	Table V	1
7	Washer, Flat 3/8 Wide	Table V	2
8	Screw, HHC 3/8-16NC X 4-1/2	Table V	1
9	Nut, Hex Elastic Lock 3/8-16NC	Table V	1
10	End Stop	Table V	2
11	Blade	Table V	Table V
12	Screw, HHC 3/8-16NC X 2	Table V	2
13	Label, Conveyor Products Warning	23395	2
14	Label, Martin® Products	38048	2

Figure 9b. Martin® DT2 Inline Cleaner Cartridge, P/N DT2SC-XXXXXXXXXX

Table V. Martin® DT2 Inline Cleaner Cartridge

Part No. Std-Duty Mainframe	Dim "A"	Dim "B"	Dim "C"	Dim. "E" Blade Type	
				T, S, U	A
DT2SC-18X12XXXX	36.16 (918)	27.00 (686)	12.00 (305)	6.38 (162)	6.50 (165)
DT2SC-18X18XXXX	36.16 (918)	27.00 (686)	18.00 (457)	3.38 (86)	3.50 (89)
DT2SC-24X18XXXX	42.16 (1071)	33.00 (838)	18.00 (457)	6.38 (162)	6.50 (165)
DT2SC-24X24XXXX	42.16 (1071)	33.00 (838)	24.00 (610)	3.38 (86)	3.50 (89)
DT2SC-30X24XXXX	48.16 (1223)	39.00 (991)	24.00 (610)	6.38 (162)	6.50 (165)
DT2SC-30X30XXXX	48.16 (1223)	39.00 (991)	30.00 (762)	3.38 (86)	3.50 (89)
DT2SC-36X30XXXX	54.16 (1376)	45.00 (1143)	30.00 (762)	6.38 (162)	6.50 (165)
DT2SC-36X36XXXX	54.16 (1376)	45.00 (1143)	36.00 (914)	3.38 (86)	3.50 (89)
DT2SC-42X36XXXX	60.16 (1528)	51.00 (1295)	36.00 (914)	6.38 (162)	6.50 (165)
DT2SC-42X42XXXX	60.16 (1528)	51.00 (1295)	42.00 (1067)	3.38 (86)	3.50 (89)
DT2SC-48X42XXXX	66.16 (1680)	57.00 (1448)	42.00 (1067)	6.38 (162)	6.50 (165)
DT2SC-48X48XXXX	66.16 (1680)	57.00 (1448)	48.00 (1219)	3.38 (86)	3.50 (89)
DT2SC-54X48XXXX	72.16 (1833)	63.00 (1600)	48.00 (1219)	6.38 (162)	6.50 (165)
DT2SC-54X54XXXX	72.16 (1833)	63.00 (1600)	54.00 (1372)	3.38 (86)	3.50 (89)
DT2SC-60X54XXXX	78.16 (1985)	69.00 (1753)	54.00 (1372)	6.38 (162)	6.50 (165)
DT2SC-60X60XXXX	78.16 (1985)	69.00 (1753)	60.00 (1524)	3.38 (86)	3.50 (89)
DT2SC-66X60XXXX	84.16 (2138)	75.00 (1905)	60.00 (1524)	6.38 (162)	6.50 (165)
DT2SC-66X66XXXX	84.16 (2138)	75.00 (1905)	66.00 (1676)	3.38 (86)	3.50 (89)
DT2SC-72X66XXXX	90.16 (2290)	81.00 (2057)	66.00 (1676)	6.38 (162)	6.50 (165)
DT2SC-84X78XXXX	102.16 (2595)	93.00 (2362)	78.00 (1981)	6.38 (162)	6.50 (165)
DT2SC-96X90XXXX	114.16 (2900)	105.00 (2667)	90.00 (2286)	6.38 (162)	6.50 (165)

Part Numbers

Part No. Std-Duty Mainframe	Item 1 P/N	Item 2 P/N	Qty Items 3, 4	Qty Item 11	
				T, S, U	A
DT2SC-18X12XXXX	37717-18	34423-30	2	2	4
DT2SC-18X18XXXX	37717-18	34423-30	2	3	6
DT2SC-24X18XXXX	37717-24	34423-36	3	3	6
DT2SC-24X24XXXX	37717-24	34423-36	3	4	8
DT2SC-30X24XXXX	37717-30	34423-42	3	4	8
DT2SC-30X30XXXX	37717-30	34423-42	3	5	10
DT2SC-36X30XXXX	37717-36	34423-48	4	5	10
DT2SC-36X36XXXX	37717-36	34423-48	4	6	12
DT2SC-42X36XXXX	37717-42	34423-54	4	6	12
DT2SC-42X42XXXX	37717-42	34423-54	4	7	14
DT2SC-48X42XXXX	37717-48	34423-60	5	7	14
DT2SC-48X48XXXX	37717-48	34423-60	5	8	16
DT2SC-54X48XXXX	37717-54	34423-66	5	8	16
DT2SC-54X54XXXX	37717-54	34423-66	5	9	18
DT2SC-60X54XXXX	37717-60	34423-72	5	9	18
DT2SC-60X60XXXX	37717-60	34423-72	5	10	20
DT2SC-66X60XXXX	37717-66	34423-78	6	10	20
DT2SC-66X66XXXX	37717-66	34423-78	6	11	22
DT2SC-72X66XXXX	37717-72	34423-84	6	11	22
DT2SC-84X78XXXX	37717-84	34423-96	7	13	26
DT2SC-96X90XXXX	37717-96	34423-108	8	15	30

Part No. 316 SS Mainframe	Item 1 P/N	Item 2 P/N
DT2SC-18X12XXSX	37717-18-316SS	34423-030N
DT2SC-18X18XXSX	37717-18-316SS	34423-030N
DT2SC-24X18XXSX	37717-24-316SS	34423-036N
DT2SC-24X24XXSX	37717-24-316SS	34423-036N
DT2SC-30X24XXSX	37717-30-316SS	34423-042N
DT2SC-30X30XXSX	37717-30-316SS	34423-042N
DT2SC-36X30XXSX	37717-36-316SS	34423-048N
DT2SC-36X36XXSX	37717-36-316SS	34423-048N
DT2SC-42X36XXSX	37717-42-316SS	34423-054N
DT2SC-42X42XXSX	37717-42-316SS	34423-054N
DT2SC-48X42XXSX	37717-48-316SS	34423-060N
DT2SC-48X48XXSX	37717-48-316SS	34423-060N
DT2SC-54X48XXSX	37717-54-316SS	34423-066N
DT2SC-54X54XXSX	37717-54-316SS	34423-066N

Part No. 316 SS Mainframe	Item 1 P/N	Item 2 P/N
DT2SC-60X54XXSX	37717-60-316SS	34423-072N
DT2SC-60X60XXSX	37717-60-316SS	34423-072N
DT2SC-66X60XXSX	37717-66-316SS	34423-078N
DT2SC-66X66XXSX	37717-66-316SS	34423-078N
DT2SC-72X66XXSX	37717-72-316SS	34423-084N
DT2SC-84X78XXSX	37717-84-316SS	34423-096N
DT2SC-96X90XXSX	37717-96-316SS	34423-108N

Part No.	Mainframe Type	Item 4 P/N	Item 5 P/N	Item 7 P/N	Item 8 P/N
DT2S-XXXXXXXXPX	Std Duty	17328	18577	36313	18007
DT2S-XXXXXXXXSX	316 SS	35913	SP03938-02	36313-316SS	37471

Part No.	Mainframe Type	Item 9 P/N	Item 10 P/N	Item 13 P/N
DT2S-XXXXXXXXPX	Std Duty	34082	14201	37036
DT2S-XXXXXXXXSX	316 SS	37764	SP03938-12	37763

Blade Part No.	Blade Type	Item 10 P/N	Item 11 P/N	Dim "D"
DT2SC-XXAXXXXXX	INLINE TC	37015	36316-TXX	3.00 (76)
DT2SC-XXAXXXXXSX	INLINE TC	37015-N	36316-TXX	3.00 (76)
DT2SC-XXTXXXXXX	REVERSING TC	37015	31104-TXX	6.00 (152)
DT2SC-XXTXXXXSX	REVERSING TC	37015-N	31104-TXX	6.00 (152)
DT2SC-XXSXXXXXX	REVERSING SS	37015	31104-SXX	6.00 (152)
DT2SC-XXSXXXXSX	REVERSING SS	37015-N	31104-SXX	6.00 (152)
DT2SC-XXUXXXXXX	REVERSING URETHANE	37015	31104-UXX	6.00 (152)
DT2SC-XXUXXXXSX	REVERSING URETHANE	37015-N	31104-UXX	6.00 (152)

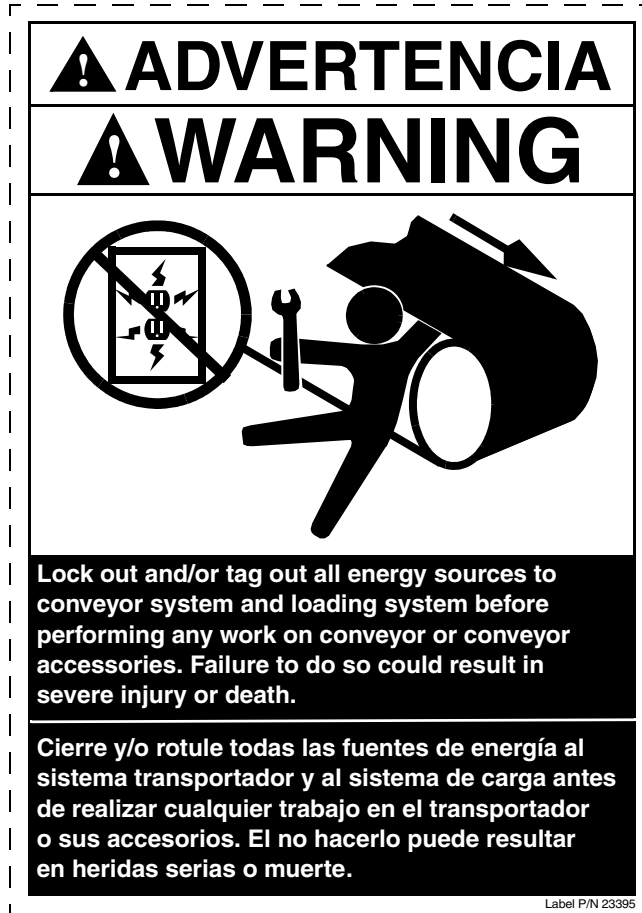

Figure 10. Martin[®] Conveyor Products Warning Label, P/N 23395



Figure 11. Martin[®] Pinch Point Warning Label, P/N 30528

Any product, process, or technology described here may be the subject of intellectual property rights reserved by Martin Engineering Company. Trademarks or service marks designated with the ® symbol are registered with the U.S. Patent and Trademark Office and may be proprietary in one or more countries or regions. Other trademarks and service marks belonging to Martin Engineering Company in the United States and/or other countries or regions may be designated with the “TM” and “SM” symbols. Brands, trademarks, and names of other parties, who may or may not be affiliated with, connected to, or endorsed by Martin Engineering Company, are identified wherever possible. Additional information regarding Martin Engineering Company’s intellectual property can be obtained at www.martin-eng.com/trademarks.

Problem Solved™
GUARANTEED!



Martin Engineering USA

One Martin Place
Neponset, IL 61345-9766 USA
800 544 2947 or 309 852 2384
Fax 800 814 1553
www.martin-eng.com

**COMPANY WITH
QUALITY SYSTEM
CERTIFIED BY DNV
= ISO 9001:2008 =**