



Martin[®] QC2[™] Cleaner

[Go to Martin[®] QC2[™] Cleaner web page](#)



Operator's Manual
M3429

Important

MARTIN ENGINEERING HEREBY DISCLAIMS ANY LIABILITY FOR: DAMAGE DUE TO CONTAMINATION OF THE MATERIAL; USER'S FAILURE TO INSPECT, MAINTAIN AND TAKE REASONABLE CARE OF THE EQUIPMENT; INJURIES OR DAMAGE RESULTING FROM USE OR APPLICATION OF THIS PRODUCT CONTRARY TO INSTRUCTIONS AND SPECIFICATIONS CONTAINED HEREIN. MARTIN ENGINEERING'S LIABILITY SHALL BE LIMITED TO REPAIR OR REPLACEMENT OF EQUIPMENT SHOWN TO BE DEFECTIVE.

Observe all safety rules given herein along with owner and Government standards and regulations. Know and understand lockout/tagout procedures as defined by American National Standards Institute (ANSI) z244.1-1982, *American National Standard for Personnel Protection - Lockout/Tagout of Energy Sources - Minimum Safety Requirements* and Occupational Safety and Health Administration (OSHA) Federal Register, Part IV, 29 CFR Part 1910, *Control of Hazardous Energy Source (Lockout/Tagout); Final Rule*.

The following symbols may be used in this manual:



Danger: Immediate hazards that will result in severe personal injury or death.



Warning: Hazards or unsafe practices that could result in personal injury.



Caution: Hazards or unsafe practices that could result in product or property damages.



Important: Instructions that must be followed to ensure proper installation/operation of equipment.



Note: General statements to assist the reader.

Table of Contents

Section	Page
List of Figures/Tables	ii
Introduction	1
General	1
Installations without chutework	1
Belt cleaner inspection access	1
References	1
Safety	2
Urethane Shelf Life	3
Before Installing Belt Cleaner and Tensioner	4
Installing Belt Cleaner Assembly	5
Installing tensioners	5
Installing belt cleaner mainframe	8
Tensioning belt cleaner	12
After Installing Belt Cleaner and Tensioner	14
Weekly Maintenance	15
Troubleshooting	18
Part Numbers	19
Appendix	A-1

List of Figures

Figure	Title	Page
1	Martin® QC2™ Cleaner Assembly, P/N 35700-XXXXXXX	20
2	Conveyor Products Warning Label, P/N 23395	22
3	Martin® QC2™ Tensioning Label, P/Ns 36073-L and 36073-R	22

List of Tables

Table	Title	Page
I	Urethane Shelf Life.....	3

Introduction

General

To introduce product back into the product flow, a Pre-Cleaner is installed on the face of the head pulley. On a dual cleaner system, the Secondary Cleaner is installed immediately following the Pre-Cleaner to remove stubborn material left on the conveyor belt. If a Pre-Cleaner cannot be used because of space limitations, the Secondary Cleaner is installed alone. If the material-handling process or product could be affected by contamination from the use of these belt cleaners, the user is responsible for taking the necessary steps to prevent contamination. Consult Martin Engineering or a representative for alternate belt cleaners or belt cleaner locations to use where contamination may be an issue.

Installations without chutework

These procedures were written for equipment that is being installed on enclosed pulley chutework. If the pulley is not enclosed, the equipment should be installed using the best available field resources and methods to ensure that the critical dimensions are followed for proper installation.

Belt cleaner inspection access

If the belt cleaner is installed on enclosed pulley chutework, a Martin[®] Inspection Door should be installed. Martin[®] Inspection Doors are available from Martin Engineering or a representative.

References

The following documents are referenced in this manual:

- American National Standards Institute (ANSI) z244.1-1982, *American National Standard for Personnel Protection - Lockout/Tagout of Energy Sources - Minimum Safety Requirements*, American National Standards Institute Inc., 1430 Broadway, New York, NY 10018.
- Federal Register, Volume 54, Number 169, Part IV, 29 CFR Part 1910, *Control of Hazardous Energy Source (Lockout/Tagout); Final Rule*, Department of Labor, Occupational Safety and Health Administration (OSHA), 32nd Floor, Room 3244, 230 South Dearborn Street, Chicago, IL 60604.

Safety

All safety rules defined in the above documents and all owner/employer safety rules must be strictly followed when working on the belt cleaner.



⚠ DANGER

Do not touch or go near the conveyor belt or conveyor accessories when the belt is running. Your body or clothing can get caught and you can be pulled into the conveyor, resulting in severe injury or death.



⚠ DANGER

Before installing, servicing, or adjusting the belt cleaner, turn off and lock out/tag out all energy sources to the conveyor and conveyor accessories according to ANSI standards. Failure to do so could result in serious injury or death.

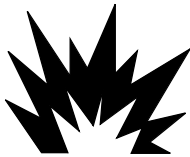

⚠ DANGER

If this equipment will be installed in an enclosed area, test the gas level or dust content before using a cutting torch or welding. Using a torch or welding in an area with gas or dust may cause an explosion resulting in serious injury or death.



⚠ WARNING

Before using a cutting torch or welding the chute wall, cover the conveyor belt with a fire retardant cover. Failure to do so can allow the belt to catch fire.

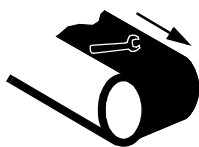

⚠ WARNING

Remove all tools from the installation area and conveyor belt before turning on the conveyor. Failure to do so can cause serious injury to personnel or damage to the belt and conveyor.



⚠ WARNING

Mainframe with blade can be heavy and may require two people to lift. Attempting to lift the belt cleaner without assistance could result in injury.

Urethane Shelf Life

IMPORTANT

Urethane put in service after exceeding its shelf life may wear differently and deteriorate quicker than normal urethane.

NOTE

Code Date is written near bottom of blade as mm/dd/yy-x. In addition to or in place of this date, you may see an imprinted date medallion similar to the example shown. In this example, “10” stands for the year 2010. The small circles represent the months of the year and are “punched” to indicate what month the blade was produced. If code date on your blade(s) is not legible or is missing, contact Martin Engineering or a representative.

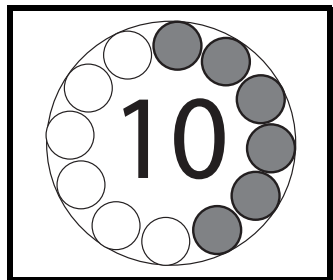

Table I. Urethane Shelf Life

Blade Color	Shelf Life
Blue	1 Year from Code Date
Brown	2 Years from Code Date
Clear	1 Year from Code Date
Green	2 Years from Code Date
Maximizer (orange)	1 Year from Code Date
Orange (A-9)	1 Year from Code Date

Before Installing Belt Cleaner

IMPORTANT

The delivery service is responsible for damage occurring in transit. Martin Engineering CANNOT enter claims for damages. Contact your transportation agent for more information.

1. Inspect shipping container for damage. Report damage to delivery service immediately and fill out delivery service's claim form. Keep any damaged goods subject to examination.
2. Remove belt cleaner assembly from shipping container.
3. If anything is missing contact Martin Engineering or a representative.



WARNING

Before installing equipment, turn off and lock out/ tag out all energy sources to the conveyor and conveyor accessories according to ANSI standards. Failure to do so could result in serious injury or death.

4. Turn off and lock out/tag out energy source according to ANSI standards (see "References").

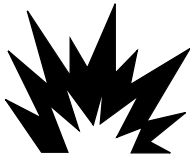

DANGER

If this equipment will be installed in an enclosed area, test the gas level or dust content before using a cutting torch or welding. Using a torch or welding in an area with gas or dust may cause an explosion resulting in serious injury or death.

5. If using a cutting torch or welding, test atmosphere for gas level or dust content. Cover conveyor belt with fire retardant cover.

IMPORTANT

Center the belt cleaner blades to clean an area narrower than the conveyor belt width. This allows for side-to-side movement of the belt and prevents damage to the belt edge.

NOTE

The chute wall that the tensioner will be located on is referred to as the "operator side." The other side of the chute is referred to as the "far side." (If installing dual tensioners, side that is most accessible is "operator side.")

6. Determine which side of chute is easiest to access. Locate the tensioner on the most accessible chute wall.

Installing Belt Cleaner Assembly

Installing tensioners

1

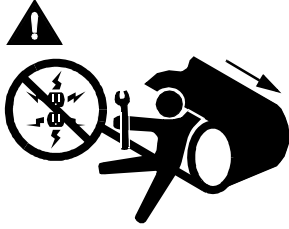

2

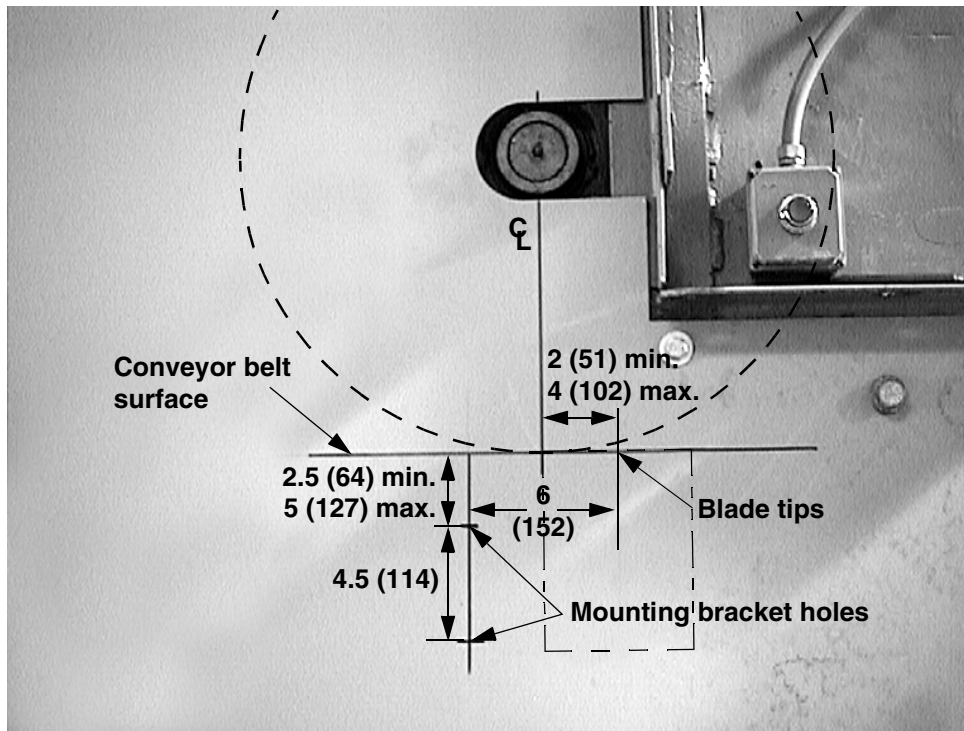

3

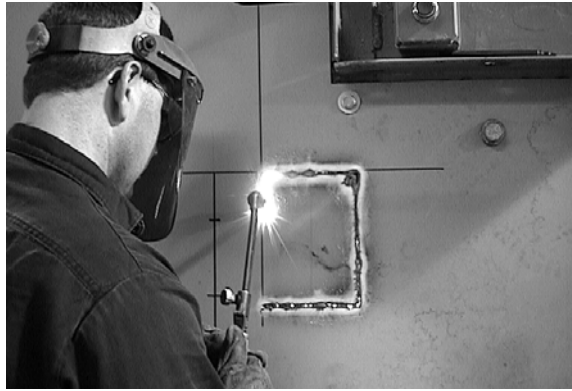
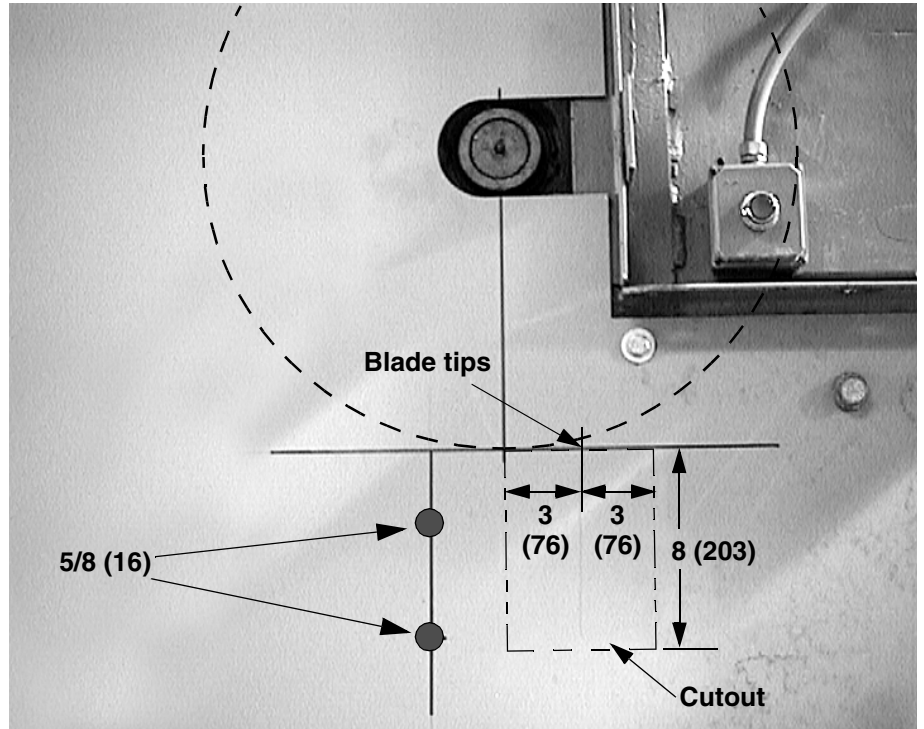

4 Weld or bolt mounting bracket to chute wall.
(Martin Engineering recommends bolting.)

5

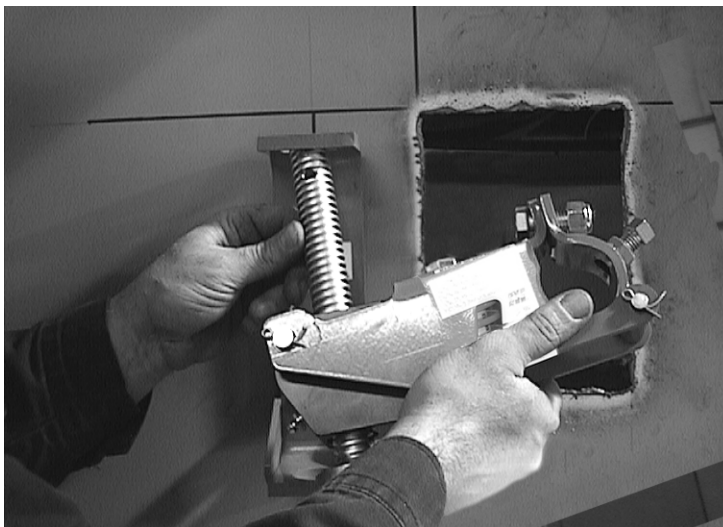

6

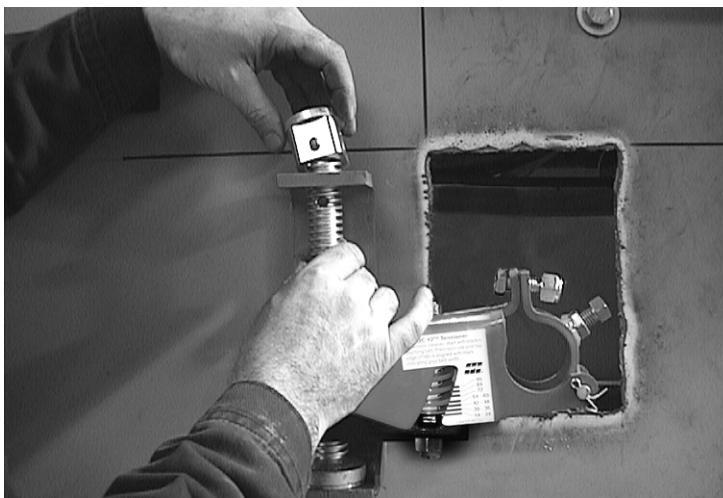

7

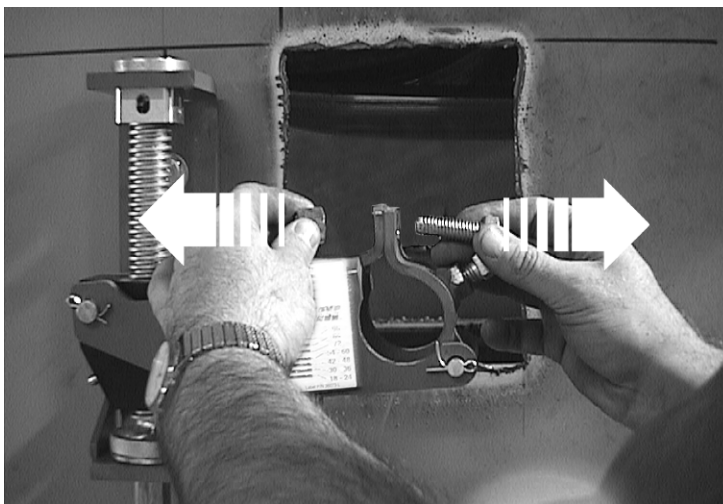

8 Repeat steps 2 through 7 on far side of chute.

Installing belt cleaner mainframe

1

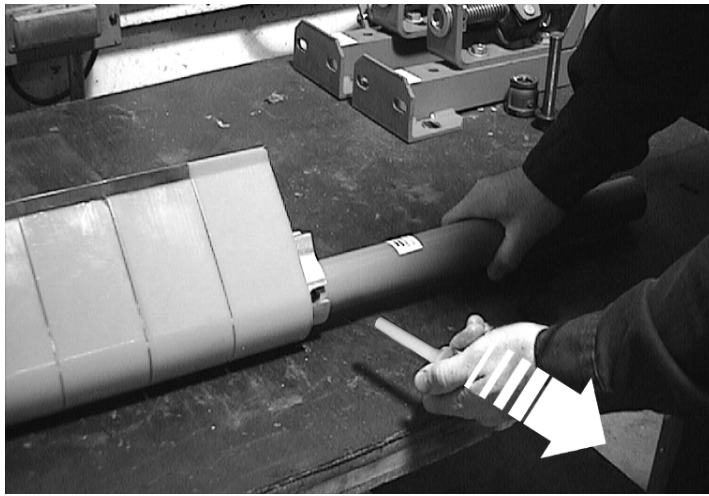

2

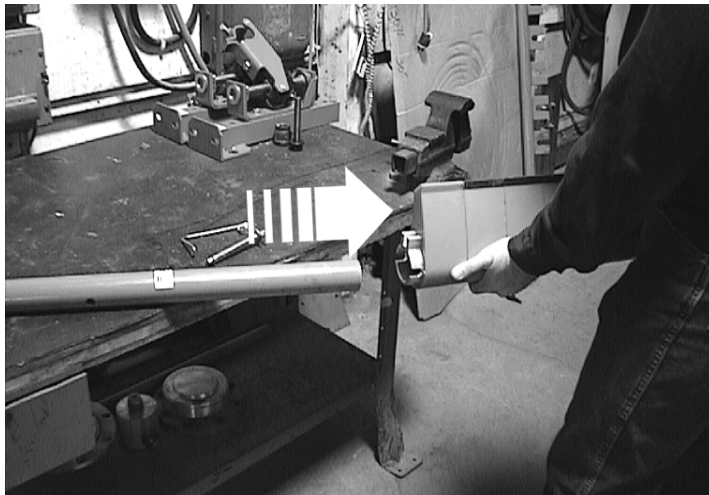

3

IMPORTANT

Install mainframe so spring pin is on far side of chute.

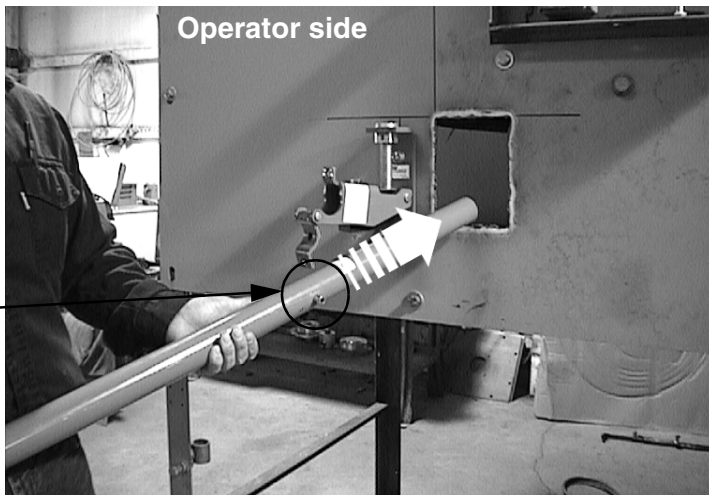

4



5

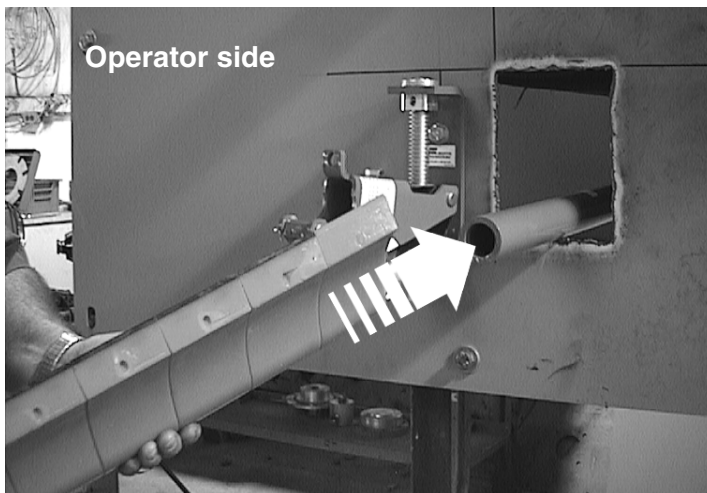
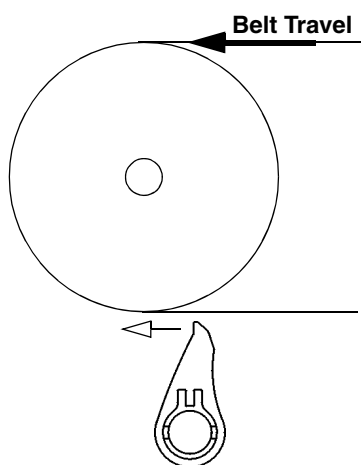

Installation

6

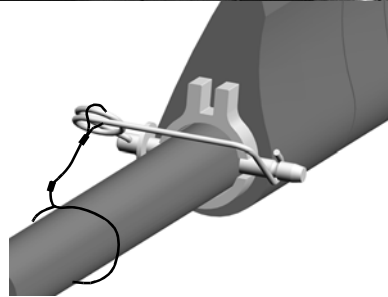
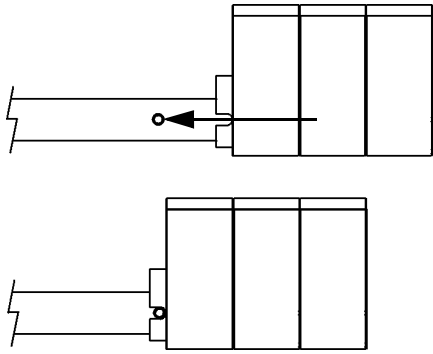

7

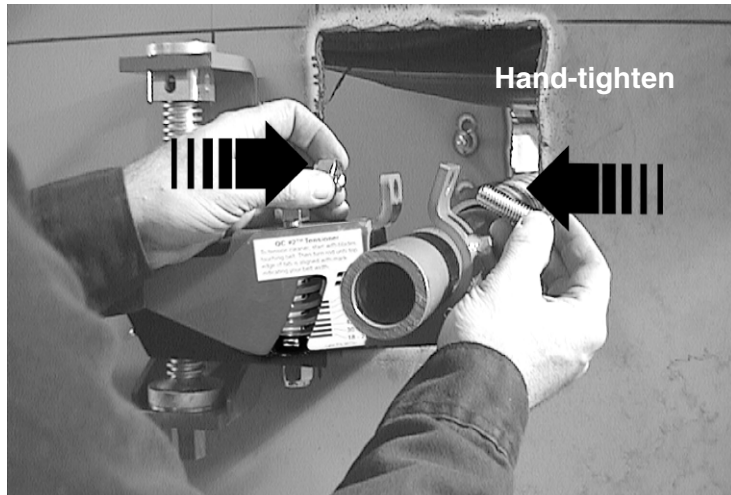

8 Adjust mainframe to ensure blades are centered on belt.

9

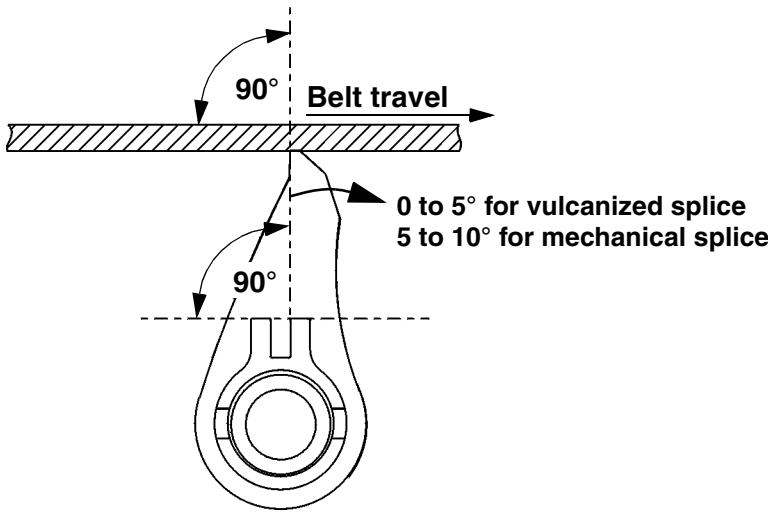

10



11

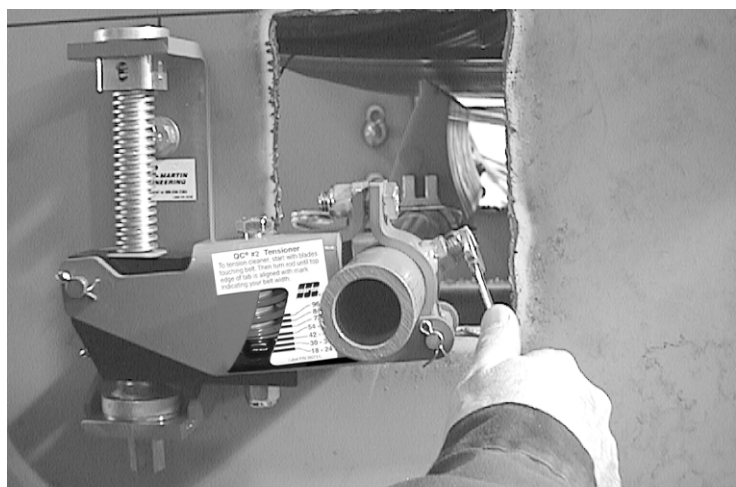

12 Repeat steps 10 and 11 on far side of chute.

Tensioning belt cleaner

- 1 Turn hex nut on the threaded rod until top of tab is aligned to belt width indicated on tensioner labels.

IMPORTANT

Before tensioning, rotate threaded rods so blades are just touching belt.

Martin® QC2™ Tensioner

To tension cleaner, start with blades touching belt. Then turn rod until top edge of tab is aligned with mark indicating your belt width.

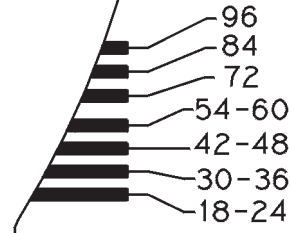

Label P/N 36073-L

- 2

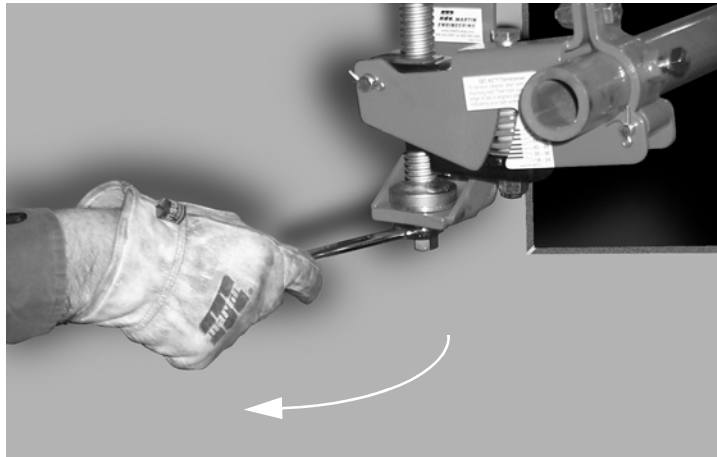

3

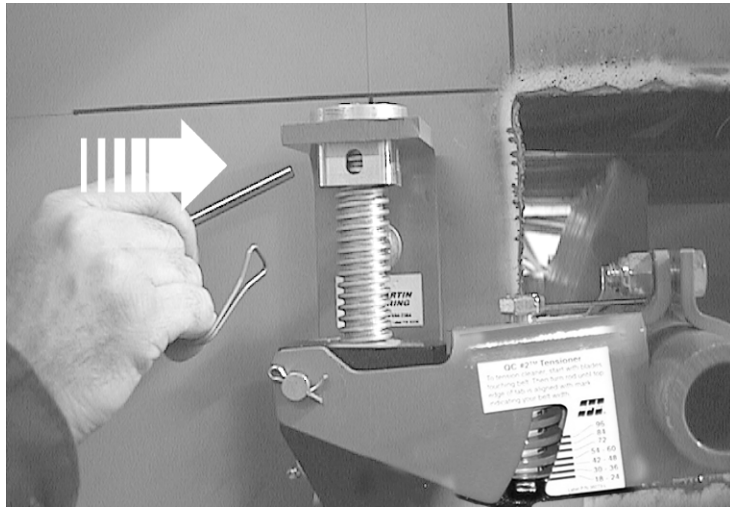

4 Repeat steps 1 through 3 on far side of chute.

After Installing Belt Cleaner



1. Thoroughly wipe chute wall clean above tensioner.
2. Place Conveyor Products Warning Label (P/N 23395) on outside chute wall visible to belt cleaner operator.

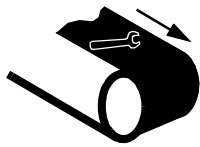

WARNING

Failure to remove tools from installation area and conveyor belt before turning on energy source can cause serious injury to personnel and damage to belt.



DANGER

Do not touch or go near conveyor belt or conveyor accessories when conveyor belt is running. Body or clothing can get caught and pull body into conveyor belt, causing severe injury or death.

3. Turn on conveyor belt for 1 hour, then turn off.



DANGER

Before installing, servicing, or adjusting the belt cleaner/tensioner, turn off and lock out/tag out all energy sources to the conveyor and conveyor accessories according to ANSI standards. Failure to do so could result in serious injury or death.

4. Make sure all fasteners are tight. Tighten if necessary.
5. Make sure cleaner is not changing belt line. If it is, install belt support ahead of blade-to-belt contact point (Secondary Cleaner).
6. Inspect belt cleaner for the following:
 - Wear. (A small amount of “break-in” wear may be found. This will stop once blades wear to conveyor belt contour.)
 - Material buildup. (No material between blades and return side of conveyor belt should be found.)
7. If wear, material buildup, or some other problem exists, see “Troubleshooting.”

NOTE

Maintenance inspection should be performed no less than weekly. Some applications may require more frequent maintenance inspections.



⚠ DANGER

Before installing, servicing, or adjusting the belt cleaner/tensioner, turn off and lock out/tag out all energy sources to the conveyor and conveyor accessories according to ANSI standards. Failure to do so could result in serious injury or death.

1. Remove any material from belt cleaner.
2. Make sure all fasteners are tight. Tighten if necessary.
3. Check tension on cleaner. Re-tension if necessary.
4. Wipe all labels clean. If labels are not readable, contact Martin Engineering or a representative for replacements.

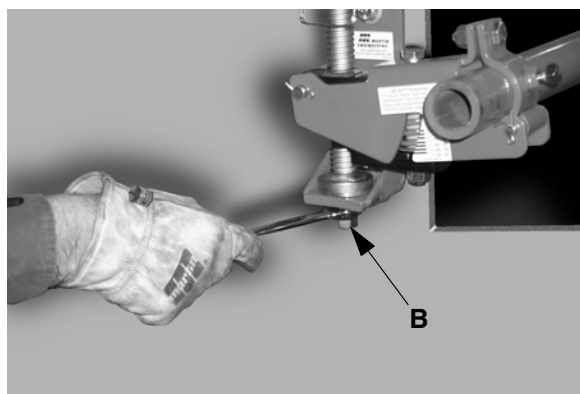
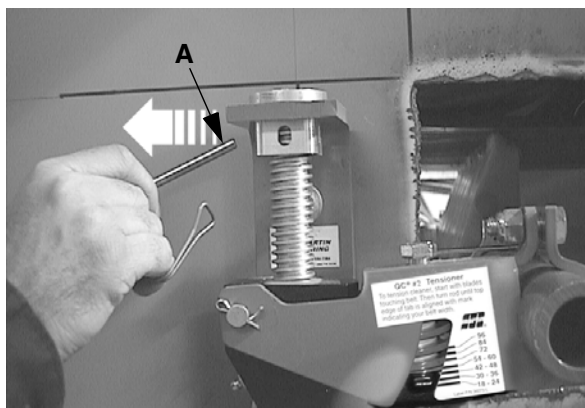

5. Check blades for excessive wear. If tungsten carbide is worn off blades, replace blade cartridge as follows:
 - a. Remove lock pin (A) from tensioner.
 - b. Turn tensioning rod (B) to lower mainframe.
 - c. Repeat steps a and b on far side tensioner.

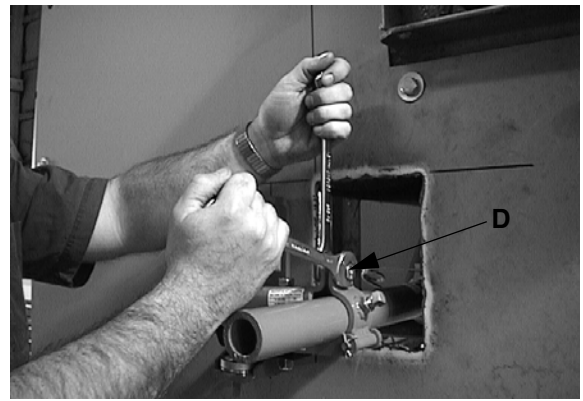
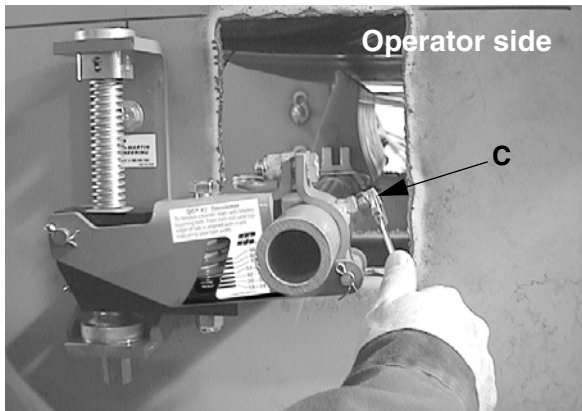

- d. Loosen set screw (C).
- e. Remove cap screw and nut (D).

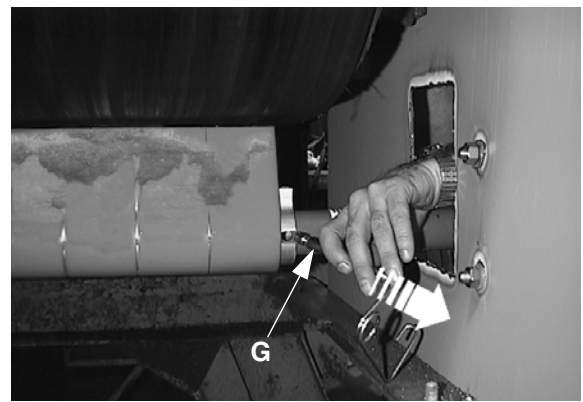
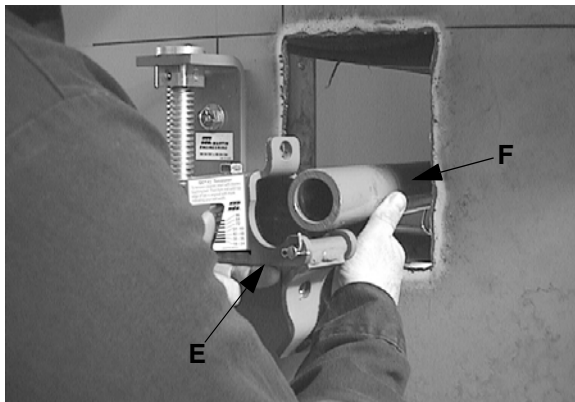

- f. Rotate tensioner bracket (E) out of the way and lower mainframe (F).
 - g. Remove lock pin (G) from mainframe.
 - h. Remove blade cartridge (H) from mainframe.
 - i. Insert new blade cartridge as shown in steps 4 through 11 under "Installing belt cleaner mainframe."
6. Remove equipment from service if there is any indication it is not functioning properly. Call Martin Engineering or a representative for assistance. Do NOT return equipment to operation until the cause of the problem has been identified and corrected.

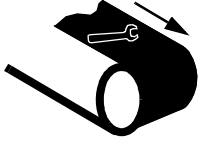

⚠ WARNING

Failure to remove tools from maintenance area and conveyor belt before turning on energy source can cause serious injury to personnel and damage to belt.

7. Remove all tools from maintenance area.

⚠ DANGER

Do not touch or go near conveyor belt or conveyor accessories when conveyor belt is running. Body or clothing can get caught and pull body into conveyor belt, causing severe injury or death.

8. Start conveyor belt.



Troubleshooting

Symptom	Corrective Action
Insufficient cleaning and carryback.	<ul style="list-style-type: none"> • Tension of cleaner on belt is set too low or too high. Increase or decrease tensioner setting. • Blades are worn. Check blades and replace if necessary.
Noise or vibration.	Tension is not sufficient or is set too high. Correct tension as necessary. If this does not correct problem, blade urethane may not match application. Contact Martin Engineering or representative.
High blade wear rate.	Tension of cleaner on belt is set too high. Reduce tensioner setting.
Unusual wear or damage to blades.	Check belt splice(s) and repair as necessary.
Bent or broken mainframe or support frame due to blade slipping through.	If blades are worn to or past the wear line, replace blades. If blades are not worn, check mainframe location.
Corrosion or chemical degradation.	Blade urethane may not match application. Contact Martin Engineering or representative.

NOTE

Conveyor equipment such as conveyor belt cleaners are subject to a wide variety of bulk materials characteristics and often have to perform under extreme operating or environmental conditions. It is not possible to predict all circumstances that may require troubleshooting. Contact Martin Engineering or a representative if you are experiencing problems other than those listed in the “Troubleshooting” chart above. Do not return the equipment to operation until the problem has been identified and corrected.

Installation checklist

If after taking the corrective actions suggested under “Troubleshooting” you are still experiencing problems, check for the following:

Installation Checklist
✓ Pre-Cleaner mainframe is proper distance from belt surface on both ends of mainframe.
✓ Pre-Cleaner blade tip is at or below horizontal center line of pulley and does not lie in path of material flow.
✓ Secondary Cleaner blade tip is 2 in. (51 mm) past vertical center line of pulley.
✓ Secondary Cleaner is not changing belt line.
✓ Blades are centered on belt.

Part Numbers

Martin[®] QC2[™] Cleaner

P/N 35700-XXXXXXXX. See Figure 1. Includes blade cartridge, mainframe and tensioners.

Martin[®] QC2[™] Tensioners

P/N 35701. See Figure 1. Includes two tensioners.

Martin[®] QC2[™] Blade Cartridges

P/N 35697-XXXXXXXX. Includes replacement blades.

Martin[®] QC2[™] Inspection Doors

Martin[®] QC2[™] Cover Door Assembly: P/N 35857. See Figure 1.
Martin[®] QC2[™] Dust-Tight Cover Door Assembly: P/N 38014-QC2.

Miscellaneous

Heavy-duty Hanger Mount Assembly: P/N 34233-HD. Used to mount Martin[®] QC2[™] Tensioners onto stringer instead of onto chute wall.

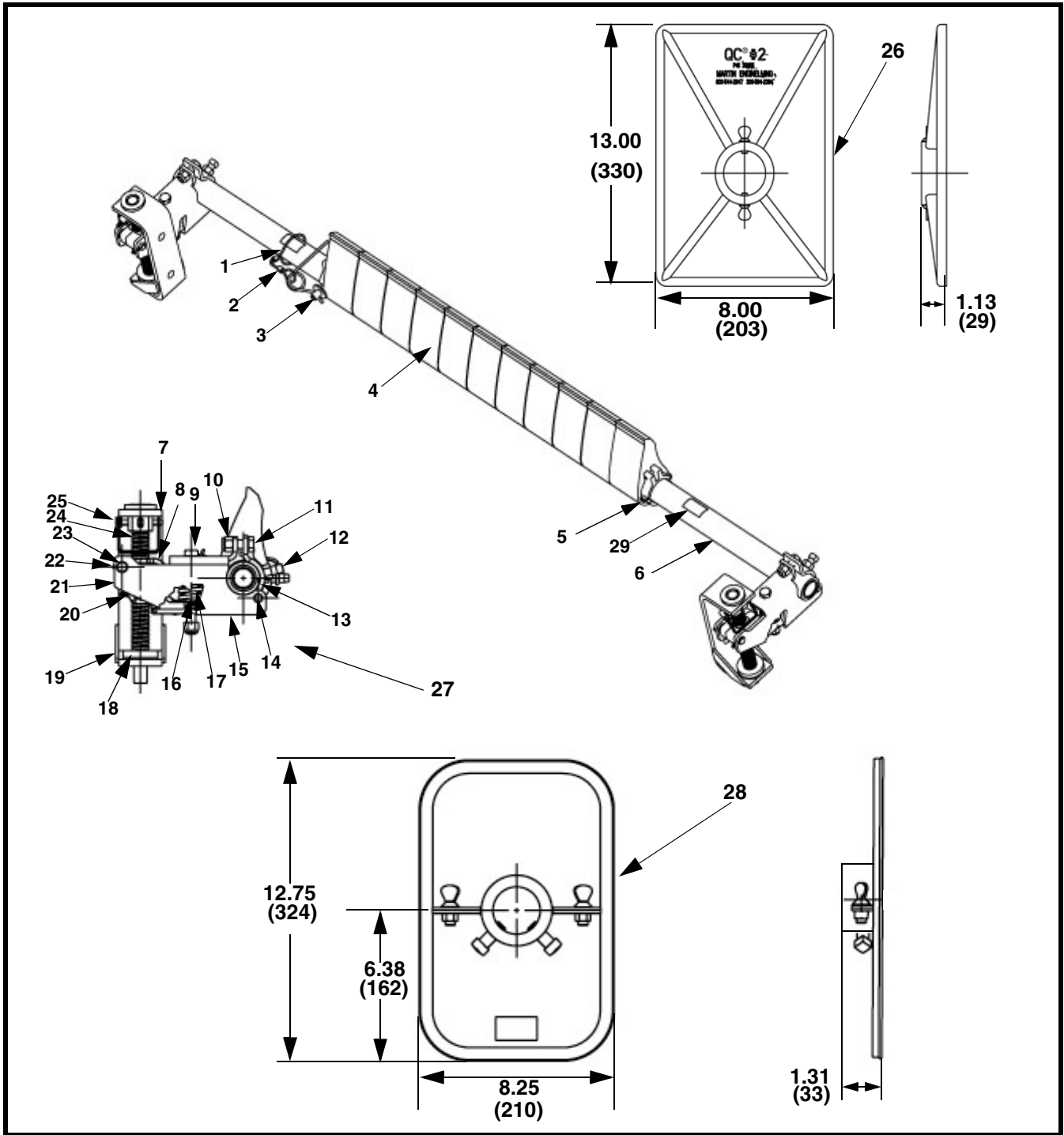

Figure 1. Martin® QC2™ Cleaner Assembly, P/N 35700-XXXXXXX* with
 Martin® QC2™ Cover Door Assembly, P/N 35857 and
 Martin® QC2™ Dust-Tight Cover Door Assembly, P/N 38014-QC2 (Sheet 1 of 2)

Item	Description	Part No.	Qty
1	Aircraft Cable Ø 1/8	100107	2
2	Cable Clip 1/8	23481	2
3	Snap Lock Pin 1/2	33841	1
4	Replacement Blade Cartridge	35697-XXXXXX*	1
5	Slotted Spring Pin 1/2 x 3 ZP	33840	1
6	Mainframe	35694-XX**	1
7	Tensioner Top Bushing	35683	2
8	Tensioner Pivot Block Insert	35684	2
9	Clevis Pin 1/2 x 4-1/2 ZP	SP01323-20	2
10	Hex Elastic Lock Nut 1/2 -13NC ZP	18577	2
11	Screw HHC 1/2 -13NC x 1-1/2 ZP	11763	2
12	Screw SHS Cup 1/2 -13NC x 1 SS	22763-03	2
13	Tensioner Hinge Clamp Weldment	35677	2
14	Clevis Pin 3/8 x 2-1/2 ZP	35687	2
15	Formed Arm Clamp	36070	2
16	Spring Damper Tube	17239-2.5	2
17	Die Spring 1.50 x 3.00	36072	2
18	Tensioner Bottom Bushing	35674	2
19	Mount Bracket Weldment	35672	2
20	Grease Fitting 1/8 -27 NPT	11814	2
21	Tensioner Pivot Block	36071	2
22	Cotter Pin 1/8 x 3/4 SS	31297	6
23	Clevis Pin 1/2 x 2-1/2 ZP	35686	2
24	Tensioning Rod	35682	2
25	Wire Lock Pin 1/4 x 2.25 ZP	35685	2
NS	Flat Nylon Washer 1/2	35688	4
NS	Mounting Hardware Kit	35283	1
NS	Slotted Spring Pin 1/4 x 1-1/4 SS	32403	2
26	Martin [®] QC2™ Cover Door Assembly	35857	1
27	Martin [®] QC2™ Tensioner	35701	1 Pair
28	Martin [®] QC2™ Dust-Tight Cover Door Assembly	38014-QC2	1
29	Martin [®] Products Label	38048	2
Fig. 2	Conveyor Products Warning Label	23395	2
Fig. 3	Tensioning Label	36073-L	2
Fig. 3	Tensioning Label	36073-R	2

Figure 1. Martin[®] QC2™ Cleaner Assembly, P/N 35700-XXXXXX* (Sheet 2 of 2)

*First XXX indicates belt width in inches; next X indicates blade type: T for tungsten carbide, or S for stainless steel;
 next X indicates whether a cover door is included: D for urethane, S for dust tight (assembly only);
 last XX indicates blade color: none for orange, BR for brown, or GR for green.

**XX indicates belt width in inches.

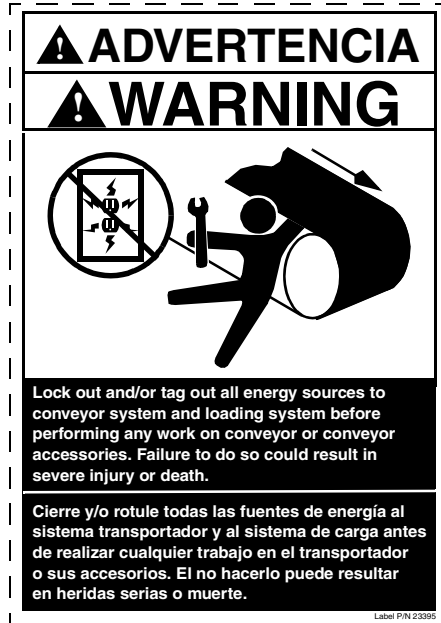

Figure 2. Conveyor Products Warning Label, P/N 23395

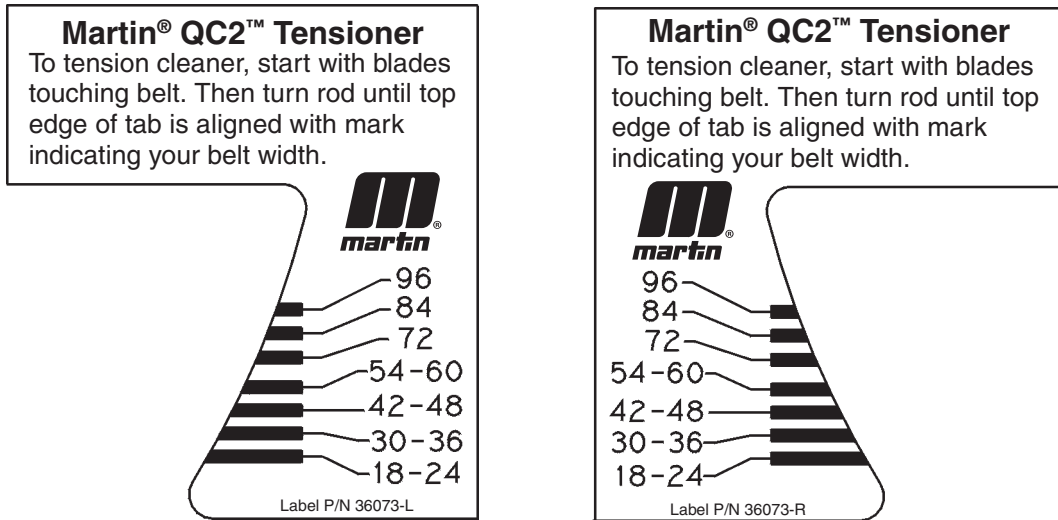
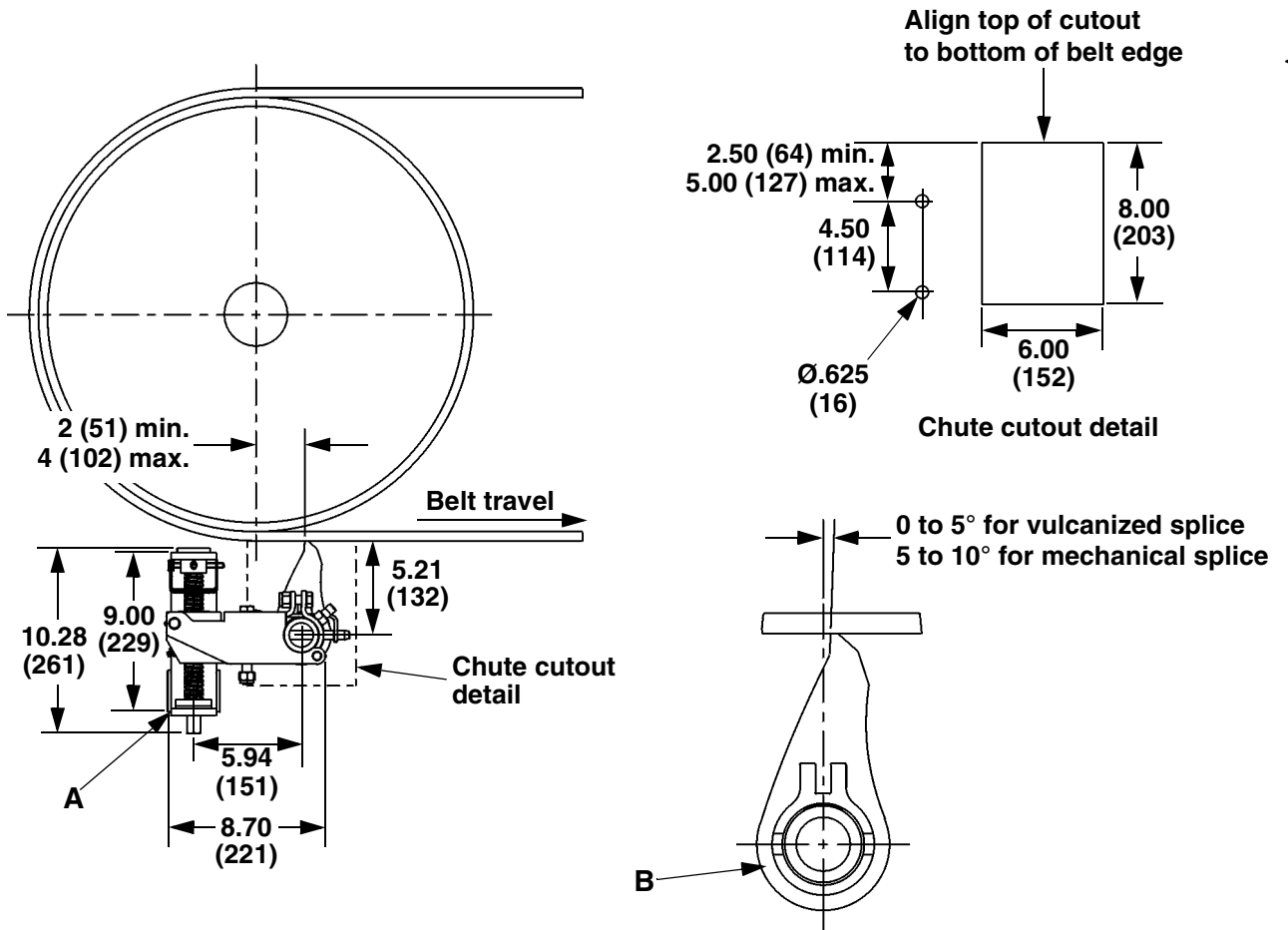

Figure 3. Martin QC2 Tensioning Labels, P/Ns 36073-L and 36073-R

Appendix

Martin® QC2™ Cleaner Assembly



- A. Martin® QC2™ Cleaner and Tensioner Assembly, P/N 35700-XXXXXX
- B. Martin® QC2™ Blade Cartridge, P/N 35697-XXXXXX

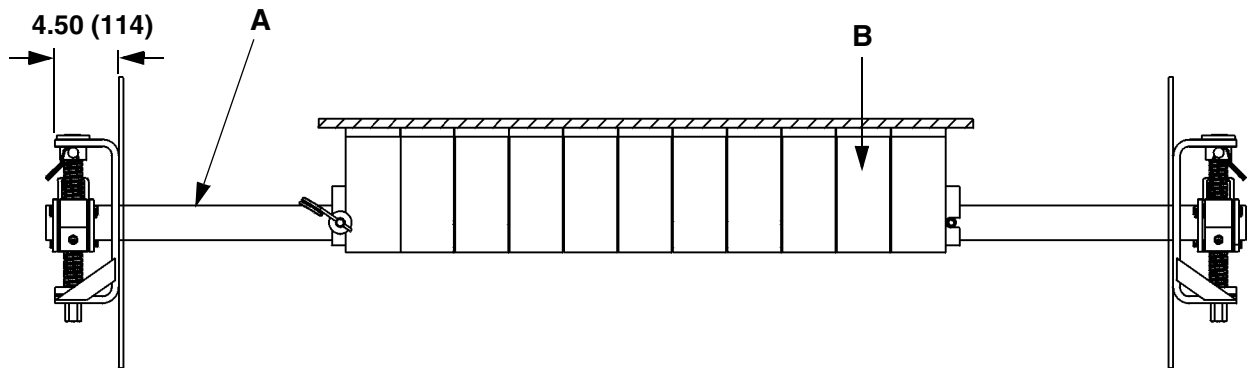

Notes

Any product, process, or technology described here may be the subject of intellectual property rights reserved by Martin Engineering Company. Trademarks or service marks designated with the ® symbol are registered with the U.S. Patent and Trademark Office and may be proprietary in one or more countries or regions. Other trademarks and service marks belonging to Martin Engineering Company in the United States and/or other countries or regions may be designated with the “TM” and “SM” symbols. Brands, trademarks, and names of other parties, who may or may not be affiliated with, connected to, or endorsed by Martin Engineering Company, are identified wherever possible. Additional information regarding Martin Engineering Company’s intellectual property can be obtained at www.martin-eng.com/trademarks.

Problem Solved™ *GUARANTEED!*



Martin Engineering USA

One Martin Place
Neponset, IL 61345-9766 USA
800 544 2947 or 309 852 2384
Fax 800 814 1553
www.martin-eng.com

**COMPANY WITH
QUALITY SYSTEM
CERTIFIED BY DNV
= ISO 9001:2008 =**