

Martin® Dust Fighter™ Foam

The **Martin® Dust Fighter™ Foam** will mix and apply a consistent dust suppression foam to control airborne dust while it minimizes the addition of moisture to the material. Specification of a Martin® Dust Fighter™ Foam requires the assistance of trained Martin Engineering personnel.

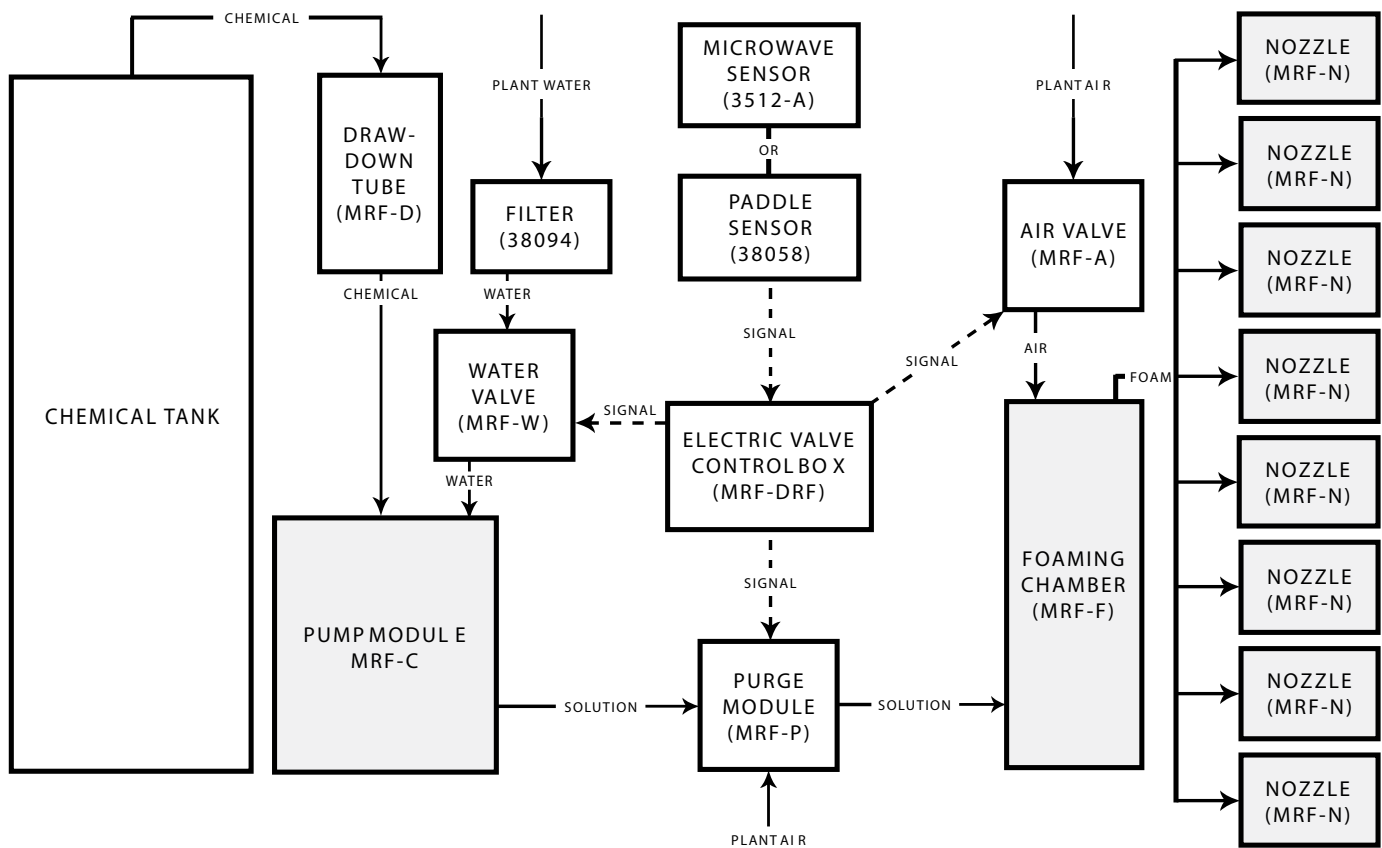

- Components shown in gray make up the basic Martin® Dust Fighter™ Foam See Page 2
- Components shown in white are optional components of the Martin® Dust Fighter™ Foam See Pages 3 & 4

Martin® Dust Fighter™ Foam, P/N MRF-X, includes the pump module, foaming chamber and up to eight nozzles. Hose (P/N 36002) is ordered by the foot.

NOTE: Chemical suppressant additive is not available from Martin Engineering.

Pump Module

P/N MRF-C

The Pump Module controls both the proportion of the chemical added to the water and the total flow of the mix of water and chemical.

Flow Rate	Pressure Range	Chemical to Water Ratio	Chemical to Water %
0.4–20 GPM 1.8–91 LPM	7–70 PSI 0.48–4.9 bar	1:500–1:66	0.2%–1.5%

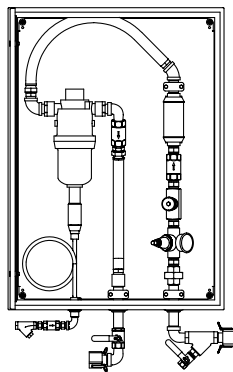

Foaming Chamber

P/N MRF-F

Air and the water/chemical mixture are combined in a Foaming Chamber to produce foam. The Foaming Chamber consists of a cylinder with inlets for the lines carrying air and the chemical/water mixture and outlets to accommodate up to 8 nozzles. The Foaming Chamber is installed at the transfer point or foam application site.

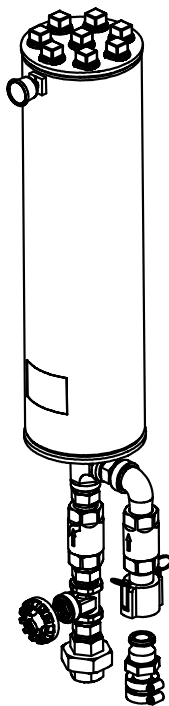
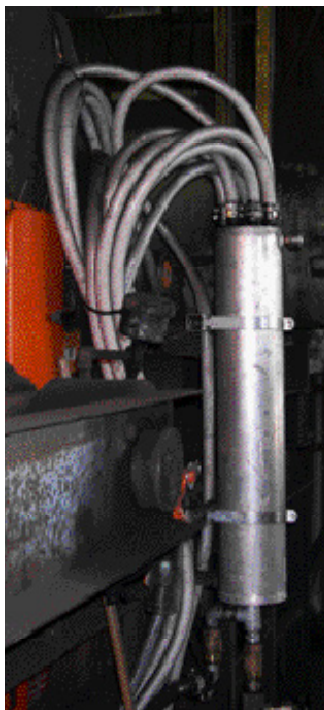

Foaming Chamber and Hoses

Nozzle Kit

P/N MRF-N

The nozzles apply foam to the material. The “duckbill” nozzles are supplied with 30 feet of corrugated hose. The nozzles are set in a cam mechanism that allows the nozzle to be removed from the chute for maintenance without requiring any tools.

Rubber Hose

P/N 36002

The length of the rubber hose that connects the **Pump Module with the Foaming Chamber** is specific to each installation. Therefore, it needs to be ordered by the foot (or meter) for each given application.

These are the base components of a Martin® Dust Fighter™ Foam. Each of these pieces operates manually. The levels are set at installation. The system is activated by opening valves to supply water and air through the system and

supply air to the system. The pump cabinet can be located close to the chemical supply tank or in a temperature-controlled environment. The foam generator is located within sight of the application points.

Yearly Service Agreement

P/N B-MT-MA-RG-SV

Foam systems require regular maintenance to perform at peak efficiency. This maintenance can include but is not limited to; unplugging nozzles and foam

lines, cleaning and changing of filters, fixing leaks and adjustment of chemical/water/air ratios. With a completed Yearly Service Agreement, Martin Engineering

commits to 12 monthly visits as well as six emergency visits by Martin Engineering’s fully equipped and trained service crews.

Optional Components

The following components are specialty items that can be installed in most applications.

The pipe fittings and any electrical components required for a dust suppression system should be

acquired to meet the requirements of each specific application.

Electrically Actuated Air and Water Valves

P/N MRF-A

P/N MRF-W

The Martin® Dust Fighter™ Foam is an all manual system, but the architecture allows the system to be easily automated by including electrical solenoid valves in the water line at the inlet of the Pump Module and at the air inlet of the Foaming Chamber. These valves are equipped with a male and female quick connect so they can be easily installed in line with the existing pump cabinet hardware. These solenoids can be driven by the plant PLC or some other method of control. Normally closed, spring loaded explosion proof solenoids were selected because they will shut the system down in the event of a power loss. MRF-A is the part number for the Air Valve and MRF-W is the part number for the Water Valve.

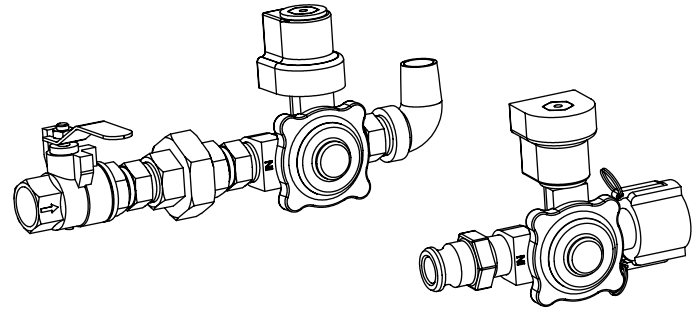

Purge Valve

P/N MRF-P

In situation where the foam system needs to be flushed out, the Purge Module is available. The purge module is installed in the solution line and is connected to an air supply. When the Purge Module receives a signal, it opens to allow air into the system components downstream to flush out the system.

The pump cabinet still needs to be heat traced or a have a heater as the cabinet can not be purged or reliably drained.

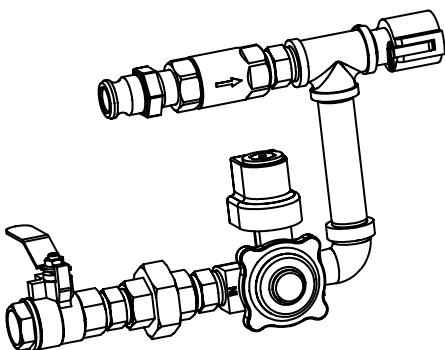

Electric Valve Control Box

P/N MRF-DRF

P/N MRF-DRF-E

A completely automatic system is available. This system features a control box that uses a signal from another procedure—this signal can come from either a plant PLC or a sensor specific to the application; for example, turning on the conveyor—to control the Water and Air Valves and Purge Module. The Control Box signal incorporates an adjustable delay. This system allows manual or automatic operation. An explosion-proof cabinet (P/N MRF-DRF-E) is available.



NOTE: All supplied solenoids are explosion proof.

Microwave Material and Flow Detector

P/N 35212-A

The Microwave Sensor uses microwaves to detect the presence of material as well as whether or not the material is moving.

Basic Material Sensor

P/N 38058

In the case where only the presence of material can be used to provide the activation signal a "paddle" sensor can be used. The paddle sensor closes a circuit to activate the dust suppression system when material on the belt pushes the paddle out of the way.

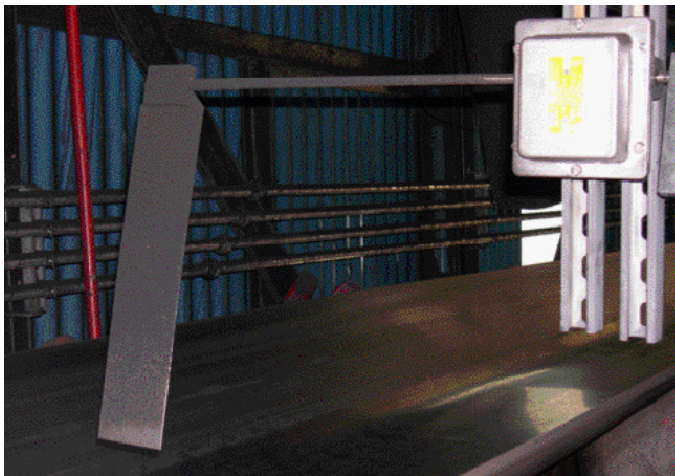

Drawdown Calibration Tube Kit

P/N MRF-D

The Drawdown Kit allows the evaluation and control of consumption of chemical additive. The kit consists of a drawdown calibration tube to test the foam chemical flow. The kit also includes the hardware necessary to easily plumb it into the chemical line.

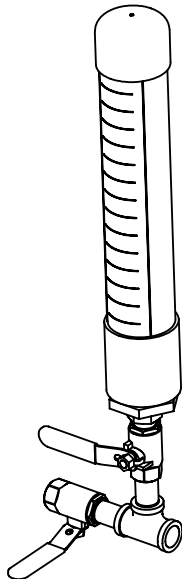

Strainer Kit

P/N 38094

If high quality water is not available, a 200 Mesh strainer kit can be installed before the Pump Module. This filter is attached to the cam lever coupler on the inlet of the pump module. Replacement filters are available (P/N 38093-B).

Tank

P/N 37153-XXXX-HTR

Martin Engineering can supply an insulated and heat traced tank in 1000, 3000, 4000 or 5000 gallon (3785, 11356, 15141 or 18927 liter) capacities. Martin Engineering can also supply a non heat-traced polyethylene tank in most capacities needed per application. Replace XXXX with required tank capacity in gallons.



Tank Plumbing Kit

P/N 37204

The Tank Plumbing Kit comes with the hardware to connect the bulkhead fitting on the bottom of the tank to the Martin® Dust Fighter™ Foam plumbing. Also included in the Tank Plumbing Kit is the connection to fill the tank from the bottom if desired. Plumbing between the tank and pump module is required and specific to individual applications.



Martin Engineering USA

One Martin Place
Neponset, IL 61345-9766 USA
800 544 2947 or 309 852 2384
Fax 800 814 1553
www.martin-eng.com

**COMPANY WITH
QUALITY SYSTEM
CERTIFIED BY DNV
= ISO 9001:2008 =**